

PT

**Turbomolecular
Pump Systems**

30 - 400 l x s⁻¹

Calibration Systems

Contents

General

General	C10.03
Applications and Accessories	C10.03

Products

Global Versions

Turbomolecular Pump Systems	
PT 50	C10.04
PT 151/PT 361	C10.08
PT 50 KIT, PT 151/PT 361 KIT	C10.12
PT 70 Dry	C10.14
PT 70 Compact	C10.16
PT 300 Dry	C10.18
PT 301 Dry	C10.20
CS Calibration Systems	C10.22
Accessories	
Delayed Venting Unit	C10.24
Adsorption Traps with Aluminium Oxide Insert	C10.26

Versions for the North and South American Continents

Turbomolecular Pump Systems	
BMH70 Dry (Dry Oil Free)	C10.28
PT-Flex	C10.30
Accessories	
TSC - TurboSystem Controller	C10.34
TPC - TurboPump Controller	C10.36

General

The requirements of production or research engineers concerning the vacuum technology they have to employ are usually widely different. In most cases pumping speed and operating pressure must be accurately matched to suit a particular process. The wide range of vacuum pumps and standard accessories available offers many options.

Sometimes it is just this flexibility which causes difficulties when having to decide between the various configurations of a particular pump system. Based on our experience and by listening to our customers' demands, we have therefore compiled a range of turn-key vacuum systems based on standard components. Before leaving the factory they are subjected to both functional

tests and leak tests. By adding components from our standard range of accessories they may be easily adapted to meet specific requirements.

Application and Accessories

Pump systems													
	PT 50	PT 151	PT 361	PT 50 Kit	PT 151 Kit	PT 361 Kit	PT 70 Dry	PT 70 Compact	PT 300 Dry	PT 301 Dry	BMH 70 Dry	PT-Flex	
Application													
Microbalances	■	■	■	■	■	■	■	■	■	■	■	■	
Sputtering	■	■	■	■	■	■	■	■	■	■	■	■	
Spectroscopy	■	■	■	■	■	■	■	■	■	■	■	■	
Production of TV and monitor picture tubes	■	■	■	■	■	■	■	■	■	■	■	■	
Surface refining	■	■	■	■	■	■	■	■	■	■	■	■	
Evaporation coating systems	■	■	■	■	■	■	■	■	■	■	■	■	
Beam guidance systems	■	■	■	■	■	■	■	■	■	■	■	■	
Laboratory pump systems	■	■	■	■	■	■	■	■	■	■	■	■	
Accessories													
	Page												
Air cooling unit	-	■	■	■	■	■	■					■	■
Flange heater	-	■	■	■	■	■	■		■	■	■	■	
Delayed venting unit	C10.24	■	■	■	■	■	■					■	■
Venting valve	-	■	■	■	■	■	■	■				■	■
Power failure venting valve	-	■	■	■	■	■	■	■	■	■	■	■	
Purge gas and venting valve	-		■	■		■	■					■	
Adsorption traps with aluminium oxide insert	C10.26	■	■	■	■	■	■					■	■
Exhaust filter	-	■	■	■	■	■	■					■	■

PT 50 Turbomolecular Pump System



This turbomolecular pump system is a fully assembled and ready-to-operate ultra high vacuum system as a table top unit for processes which require hydrocarbon-free high and ultra high vacuum.

Advantages to the User

- High effective pumping speed
- Low ultimate pressure ($< 10^{-8}$ mbar ($< 0.75 \times 10^{-8}$ Torr))
- High pumping speed of the backing pump
- Compact, small, rugged unit
- Simple to operate
- High level of reliability
- Maintenance-friendly design
- For use world-wide
- Installation of standard vacuum components in an open frame
- Components such as the backing pump, frequency converter, vacuum gauge and power failure venting valve are controlled via a rotary switch
- Service friendly assembly for maintenance without the need to disassemble backing or high vacuum pump
- The high vacuum pump can be removed from the pump system
- CE approval

The turbomolecular pump system consists of the following principal components:

- Grease lubricated turbomolecular pump TURBOVAC 50 with ceramic ball bearings, convection cooling and splinter guard
- Electronic frequency converter NT 10
- Dual-stage, oil sealed rotary vane vacuum pump TRIVAC D 2,5 E as backing pump
- Switchbox with rotary switch for driving the backing pump, the turbomolecular pump, a vacuum gauge (optional) and a power failure venting valve (optional)
- Mains connection 230 V, 50 Hz with EURO plug
- Rugged table top unit which may also carry heavy assemblies
- All required connecting and sealing components are located within the pump system assembly

The pump system is prepared for installation of further components:

- Vacuum gauge
- Power failure venting valve
- Air cooling unit
- Assembly on the intake side with manifold, valves, gauge heads etc.
- Adsorption trap
- Exhaust filter
- Rotatable castors
- Mains cable with connection plug for UK, USA, Switzerland, Japan

Typical Applications

- Spectroscopy
- Tube manufacturing
- Beam guidance systems
- Micro balances
- Sputtering and evaporation systems
- Surface physics
- Laboratory pump systems
- Production of gas Lasers

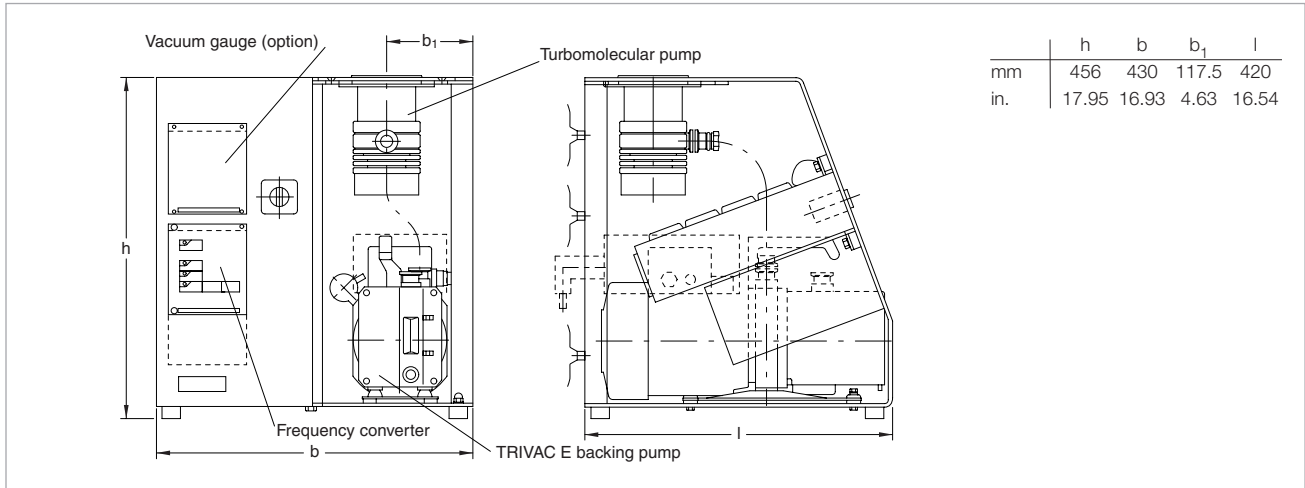

Dimensional drawing for the PT 50 turbomolecular pump system

Technical Data

PT 50

Turbomolecular pump		TURBOVAC 50	TURBOVAC 50	TURBOVAC 50
High vacuum connection	DN	40 KF	63 ISO-K	63 CF
Pumping speed for N ₂	l x s ⁻¹	33	55	55
Compression for N ₂ / H ₂		2 x 10 ⁷ / 10 ²	2 x 10 ⁷ / 10 ²	2 x 10 ⁷ / 10 ²
Speed of the TURBOVAC	rpm	72 000	72 000	72 000
Dual-stage rotary vane vacuum pump		TRIVAC D 2,5 E	TRIVAC D 2,5 E	TRIVAC D 2,5 E
nominal pumping speed				
acc. to PNEUROP	m ³ x h ⁻¹ (cfm)	2.7 (1.6)	2.7 (1.6)	2.7 (1.6)
Ultimate total pressure	mbar (Torr)	10 ⁻³ (0.75 x 10 ⁻³)	10 ⁻³ (0.75 x 10 ⁻³)	10 ⁻³ (0.75 x 10 ⁻³)
Attainable ultimate pressure				
with FPM gasket	mbar (Torr)	10 ⁻⁷ (0.75 x 10 ⁻⁷)	10 ⁻⁷ (0.75 x 10 ⁻⁷)	10 ⁻⁷ (0.75 x 10 ⁻⁷)
with aluminum or Cu gasket ¹⁾	mbar (Torr)	-	-	10 ⁻⁹ (0.75 x 10 ⁻⁹)
Main supply, 50/60 Hz	V	100-120 / 200-240 ± 5%	100-120 / 200-240 ± 5%	100-120 / 200-240 ± 5%
Rated power consumption, approx.	VA	500	500	500
Dimensions (W x H x D)	mm (in.)	430 x 456 x 420 (16.93 x 17.95 x 16.54)	430 x 456 x 420 430 x 456 x 420	430 x 456 x 420 430 x 456 x 420
Weight, approx.	kg (lbs)	27 (59.4)	27 (59.4)	27 (59.4)

¹⁾ use only for CF flanges

Ordering Information

PT 50

PT 50 turbomolecular pump system			
DN 40 KF	Part No. 128 80	-	-
DN 63 ISO-K	-	Part No. 128 81	-
DN 63 CF	-	-	Part No. 128 83
Air cooling unit			
115 V	Part No. 854 06	Part No. 854 06	Part No. 854 06
230 V	Part No. 854 05	Part No. 854 05	Part No. 854 05
Flange heater			
DN 63 CF, 115 V	Part No. 854 07	Part No. 854 07	Part No. 854 07
DN 63 CF, 230 V	Part No. 854 04	Part No. 854 04	Part No. 854 04
Delayed venting unit ¹⁾	Part No. 500 441	Part No. 500 441	Part No. 500 441
Venting valve, DN 10 KF manually operated	Part No. 173 24	Part No. 173 24	Part No. 173 24
Power failure venting valve, DN 10 KF			
24 V DC	Part No. 174 46	Part No. 174 46	Part No. 174 46
115 V, 60 Hz	Part No. 200 06 420	Part No. 200 06 420	Part No. 200 06 420
230 V, 50/60 Hz	Part No. 174 26	Part No. 174 26	Part No. 174 26
Adsorption trap, DN 16 KF Adsorbent	Part No. 854 14 Part No. 854 10	Part No. 854 14 Part No. 854 10	Part No. 854 14 Part No. 854 10
Exhaust filter AF 8	Part No. 190 50	Part No. 190 50	Part No. 190 50
Mains cord			
USA/Japan 115 V, 50/60 Hz	Part No. 200 81 090	Part No. 200 81 090	Part No. 200 81 090
USA/Japan 230 V, 50/60 Hz	Part No. 200 81 141	Part No. 200 81 141	Part No. 200 81 141
CH 230 V, 50/60 Hz	Part No. 200 81 099	Part No. 200 81 099	Part No. 200 81 099
UK 230 V, 50/60 Hz	Part No. 200 81 097	Part No. 200 81 097	Part No. 200 81 097
Connecting cable for operating the TURBOVAC outside the pump system			
3 m	Part No. 121 08	Part No. 121 08	Part No. 121 08
5 m	Part No. 121 09	Part No. 121 09	Part No. 121 09
15 m	Part No. 119 90	Part No. 119 90	Part No. 119 90

¹⁾ for 24 V DC valves

PT 151/PT 361 Turbomolecular Pump Systems



These turbomolecular pump systems are ready-to-operate vacuum units for generating a vacuum in the high and ultra-high vacuum range which is free of hydrocarbons.

When pumping aggressive or abrasive process gases, a purge gas facility must be used for the pumps.

Advantages to the User

- Low ultimate pressure ($< 10^{-7}$ mbar /Torr), free of hydrocarbons
- High effective pumping speed
- Compact, mobile unit
- Simple to operate
- High level of reliability
- Purge gas and venting ports
- Components such as backing pump, frequency converter and TURBOVAC, as well as venting or degassing are controlled via a single multi function switch
- Service friendly assembly for maintenance without the need to disassemble backing or high vacuum pump
- Pump systems prepared for installation of larger backing pumps (for barrier gas operation, for example)
- Additional mains sockets for accessories
- CE approval

The turbomolecular pump systems consists of the following principal components:

- Grease lubricated turbomolecular pump TURBOVAC 151 or 361 with splinter guard
- Electronic frequency converter NT 20
- Dual-stage, oil sealed TRIVAC D 4 B or D 16 B rotary vane vacuum pump as backing pump
- Switch box with mains power outlet and rotary switch to operate the connected units

The pump systems are prepared for installation of further components:

- Vacuum gauges (up to two):
- Adsorption trap
- Exhaust filter
- Air cooling unit
- Flange heater
- Venting valve

Typical Applications

- Spectroscopy
- Tube manufacturing
- Beam guidance systems
- Microbalances
- Sputtering and evaporation systems
- Surface physics

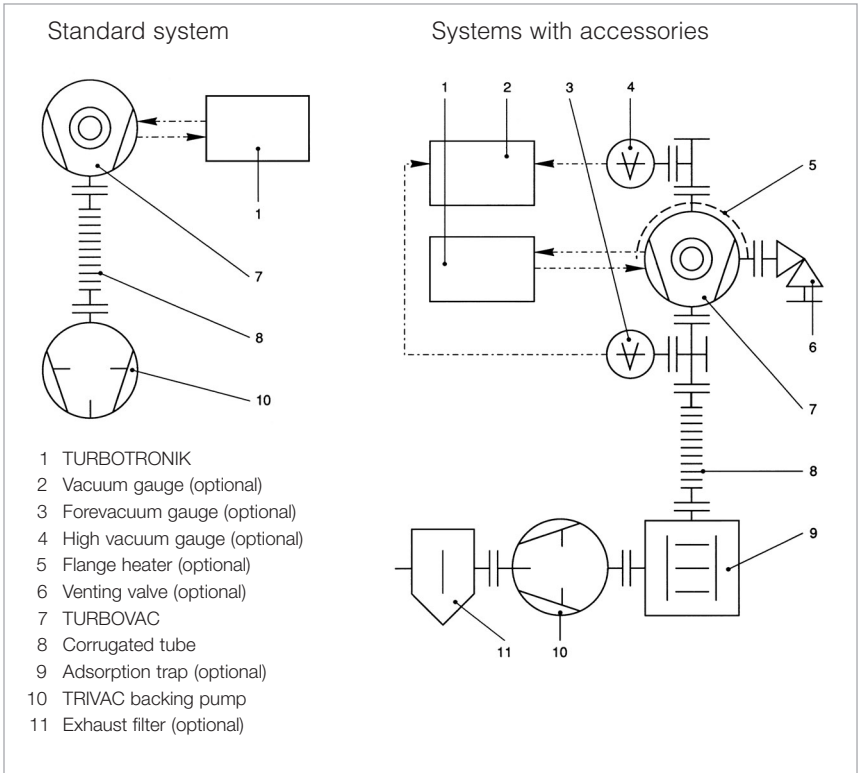

Vacuum diagram of the PT 151/PT 361 turbomolecular pump systems

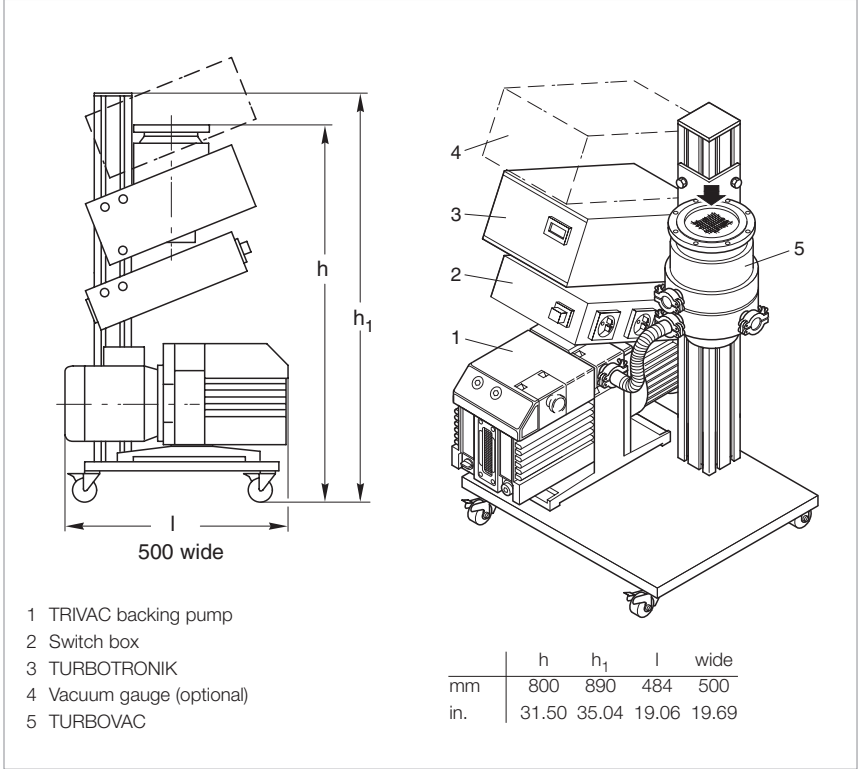

PT 151 turbomolecular pump system

Technical Data
PT 151
PT 361

		TURBOVAC 151	TURBOVAC 151	TURBOVAC 361	TURBOVAC 361
Turbomolecular pump					
High vacuum connection	DN	100 ISO-K	100 CF	100 ISO-K	100 CF
Pumping speed for N ₂	l x s ⁻¹	145	145	345	345
Compression for N ₂ /H ₂		> 10 ⁹	8.5 x 10 ²	> 10 ⁹	3.5 x 10 ³
Speed of the TURBOVAC	rpm	50 000	50 000	50 000	50 000
Dual-stage rotary vane vacuum pump		TRIVAC D 4 B	TRIVAC D 4 B	TRIVAC D 16 B	TRIVAC D 16 B
Nominal pumping speed (DIN 28 400)	m ³ x h ⁻¹ (cfm)	4.8 (2.83)	4.8 (2.83)	18.9 (11.13)	18.9 (11.13)
Exhaust connection	DN	16 KF	16 KF	25 KF	25 KF
Attainable ultimate pressure					
with FPM gasket	mbar (Torr)	10 ⁻⁸ (0.75 x 10 ⁻⁸)	10 ⁻⁸ (0.75 x 10 ⁻⁸)	10 ⁻⁸ (0.75 x 10 ⁻⁸)	10 ⁻⁸ (0.75 x 10 ⁻⁸)
with Cu seal	mbar (Torr)	–	10 ⁻¹⁰ (0.75 x 10 ⁻¹⁰)	–	10 ⁻¹⁰ (0.75 x 10 ⁻¹⁰)
Cooling water consumption	l/h	20	20	20	20
Cooling water connection, hose nozzle, outside dia.	mm (in.)	11 (0.43)	11 (0.43)	11 (0.43)	11 (0.43)
Power consumption	kW	0.7	0.7	1.5	1.5
Main supply					
EURO version		230 V, 50 Hz	230 V, 50 Hz	230 V, 50 Hz	230 V, 50 Hz
USA version		115 V, 60 Hz	115 V, 60 Hz	115 V, 60 Hz	115 V, 60 Hz
Dimensions (W x H x D)	mm (in.)	500 x 890 x 484 (19.69 x 35.04 x 19.06)	500 x 890 x 484 (19.69 x 35.04 x 19.06)	500 x 890 x 484 (19.69 x 35.04 x 19.06)	500 x 890 x 484 (19.69 x 35.04 x 19.06)
Weight, approx.	kg (lbs)	45 (99.2)	45 (99.2)	62 (136.7)	62 (136.7)

Ordering Information**PT 151****PT 361**

Turbomolecular pump system EURO version, 230 V / 50 Hz, Schuko plug DN 100 ISO-K DN 100 CF	Part No. 128 84	Part No. 128 86
	Part No. 128 85	Part No. 128 88
USA version, 115 V / 60 Hz, USA plug DN 100 ISO-K DN 100 CF	Part No. 152 57	Part No. 152 59
	Part No. 152 58	Part No. 152 60
Air cooling unit 115 V 230 V	Part No. 894 08	Part No. 894 08
	Part No. 855 31	Part No. 855 31
Flange heater, DN 100 CF 115 V 230 V	Part No. 854 28	Part No. 854 28
	Part No. 854 27	Part No. 854 27
Delayed venting unit ¹⁾	Part No. 500 441	Part No. 500 441
Venting valve, DN 10 KF manually operated	Part No. 173 24	Part No. 173 24
Power failure venting valve, DN 10 KF 24 V DC 115 V, 60 Hz 230 V, 50/60 Hz	Part No. 174 46	Part No. 174 46
	Part No. 200 06 420	Part No. 200 06 420
	Part No. 174 26	Part No. 174 26
Adsorption trap DN 16 KF DN 25 KF	Part No. 854 14	-
	-	Part No. 854 15
Adsorbent	Part No. 854 10	Part No. 854 10
Exhaust filter AF 4-8 AF 16-25	Part No. 189 06	-
	-	Part No. 189 11
Purge gas and venting valve, 230 V	Part No. 855 19	Part No. 855 19

¹⁾ for 24 V DC valves

Turbomolecular Pump Systems

PT 50 KIT, PT 151 KIT, PT 361 KIT

Under the motto "Do-it-yourself and save money" you may assemble the turbomolecular pump systems PT 50 KIT, PT 151 KIT and PT 361 KIT yourself.

The turbomolecular pump systems PT 50 KIT, PT 151 KIT and PT 361 KIT are made of the same components as used for the turn-key systems:

- Base panel with column
- Turbomolecular pump TURBOVAC 50 (PT 50 KIT) or 151 or 361 (PT 151 KIT or PT 361 KIT)
- Rotary vane vacuum pump TRIVAC D 2,5 E (PT 50 KIT) or D 4 B or D 16 B (PT 151 KIT or PT 361 KIT)
- TURBOTRONIK NT 10 electronic frequency converter (PT 50 KIT) or NT 20 (PT 151 KIT and PT 361 KIT)
- All necessary mounting parts, connection parts and gaskets are supplied
- Simple and accurate assembly instructions
- Detailed exploded view
- Description which is easy to understand
- Additional detailed knowledge is gained about the product by assembling it yourself
- CE approval

The technical data, the areas of application and the design characteristics correspond to the turbomolecular pump systems PT 50, PT 151 and PT 361 described on the preceding pages.

Typical Applications

- Spectroscopy
- Tube manufacturing
- Beam guidance systems
- Microbalances
- Sputtering and evaporation systems

PT 50 KIT



Unpacking, 15 minutes, approx.



After further 20 minutes



After further 20 minutes



After further 30 minutes

- Surface physics
- Laboratory pump systems
- Production of gas lasers

PT 151 KIT/PT 361 KIT



Unpacking, 15 minutes, approx.

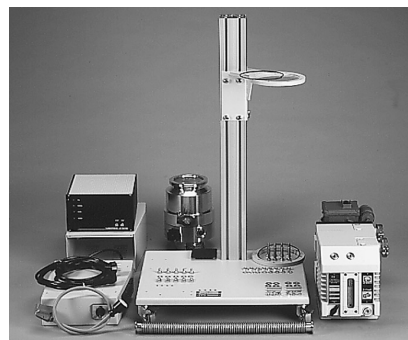

After further 30 minutes



After further 30 minutes



After further 50 minutes

Ordering Information

PT 50 KIT

PT 151 KIT

PT 361 KIT

PT 50 KIT turbomolecular pump system DN 40 KF DN 63 ISO-K DN 63 CF	Part No. 128 70 Part No. 128 71 Part No. 128 73	- - -	- - -
PT 151 KIT turbomolecular pump system, water-cooled DN 100 ISO-K DN 100 CF	- -	Part No. 128 74 Part No. 128 75	- -
PT 361 KIT turbomolecular pump system, water-cooled DN 100 ISO-K DN 100 CF DN 160 ISO-K DN 160 CF	- - - -	- - - -	Part No. 128 76 Part No. 128 78 upon request upon request
Air cooling unit 230 V 115 V	Part No. 854 05 Part No. 854 06	Part No. 855 31 Part No. 894 08	Part No. 855 31 Part No. 894 08
Flange heater DN 63 CF, 230 V DN 63 CF, 115 V DN 100 CF, 230 V DN 100 CF, 115 V	Part No. 854 04 Part No. 854 07 - -	- - Part No. 854 27 -	- - Part No. 854 27 Part No. 854 28
Adsorption trap DN 16 KF DN 25 KF Adsorbent	Part No. 854 14 - Part No. 854 10	Part No. 854 14 - Part No. 854 10	- Part No. 854 15 Part No. 854 10
Exhaust filter AF 4-8 AF 8 AF 16-25	- Part No. 190 50 -	Part No. 189 06 - -	- - Part No. 189 11
Delayed venting unit ¹⁾	Part No. 500 441	Part No. 500 441	Part No. 500 441
Venting valve, DN 10 KF manually operated	Part No. 173 24	Part No. 173 24	Part No. 173 24
Purge gas and venting valve, 230 V	-	Part No. 855 19	Part No. 855 19
Power failure venting valve, DN 10 KF 24 V DC 115 V, 60 Hz 230 V, 50/60 Hz	Part No. 174 46 Part No. 174 26 Part No. 200 06 420	Part No. 174 46 Part No. 174 26 -	Part No. 174 46 Part No. 174 26 -
Water cooling unit for the TURBOVAC	Part No. 854 08	-	-
Mains cord USA/Japan 115 V, 50/60 Hz USA/Japan 230 V, 50/60 Hz CH 230 V, 50/60 Hz UK 230 V, 50/60 Hz	Part No. 200 81 090 Part No. 200 81 141 Part No. 200 81 099 Part No. 200 81 097	- Part No. 200 81 141 Part No. 200 81 099 Part No. 200 81 097	- Part No. 200 81 141 Part No. 200 81 099 Part No. 200 81 097
Connecting cable for operating the TURBOVAC outside the pump system 3 m 5 m 10 m	Part No. 121 08 Part No. 121 09 -	- Part No. 857 66 Part No. 857 67	- Part No. 857 66 Part No. 857 67

¹⁾ for 24 V DC valves

PT 70 Dry Turbomolecular Pump System



The PT 70 Dry turbomolecular pump system is a fully assembled and ready-to-operate high vacuum system designed as a table top unit.

Advantages to the User

- Absolutely oil-free
- Low ultimate pressure free of hydrocarbons (10^{-8} mbar/Torr)
- High effective pumping speed
- Compact, small unit
- Simple operation
- High level of reliability
- Maintenance-friendly design
- Air cooling
- Installation of standard vacuum components in an open frame
- Components such as the diaphragm backing pump and turbomolecular pump are controlled via switches
- Service-friendly assembly for maintenance without the need to disassemble backing or high vacuum pump
- The high vacuum pump can be removed (installation in any orientation)
- The pump systems are subjected to a full functional test and a leak test before delivery

The turbomolecular pump system consists of the following principal components:

- TW 70 hybrid turbomolecular pump system featuring
- Integrated frequency converter

- Integrated air cooling
- Ceramic ball bearings
- Grease lubrication
- Pumping speed for nitrogen: 60 l x s^{-1}
- High vacuum connection: DN 63 ISO-K or DN 63 CF
- Integrated splinter guard
- TURBO.POWER 300 power supply. The power supply supplies the frequency converter with 24 V DC
- Dual-stage, absolutely oil-free DIVAC 0.8 T diaphragm vacuum pump used as the backing pump
- All required connection and sealing components are located within the pump system assembly

The pump system is prepared for installation of further components.

- Vacuum gauges
- Venting valve / Power failure venting valve
- Junction box

Typical Applications

- Spectroscopy
- Valve manufacturing
- Beam guidance systems
- Micro balances
- Sputtering and evaporation systems
- Surface physics
- Laboratory pump systems

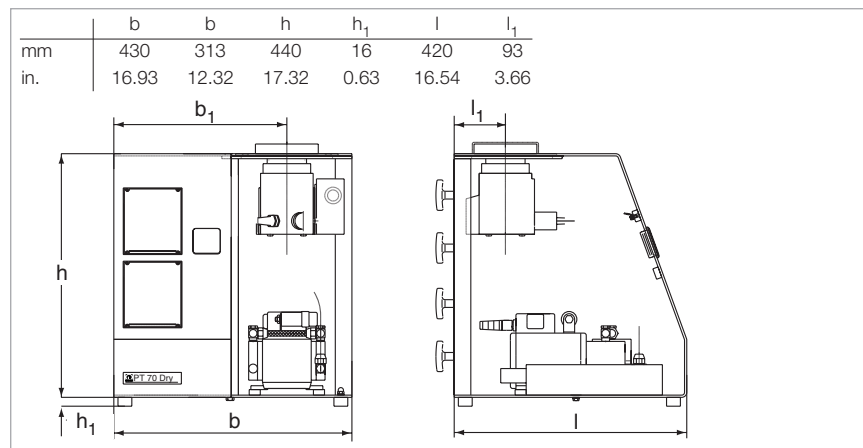

Dimensional drawing for the PT 70 Dry turbomolecular pump system

Technical Data

PT 70 Dry

Hybrid turbomolecular pump		TW 70 H	TW 70 H
High vacuum connection	DN	63 ISO-K	63 CF
Pumping speed for N ₂	l x s ⁻¹	60	60
Diaphragm pump		DIVAC 0.8 VT	DIVAC 0.8 VT
Pumping speed, approx.	m ³ x h ⁻¹ (cfm)	0.6 (0.35)	0.6 (0.35)
Ultimate pressure, approx.	mbar (Torr)	< 3 (< 2.25)	< 3 (< 2.25)
Attainable ultimate pressure	mbar (Torr)	10 ⁻⁷ (0.75 x 10 ⁻⁷)	10 ⁻⁸ (0.75 x 10 ⁻⁸)
Main supply, 50/60 Hz	V	230 / 115	230 / 115
Rated power consumption, approx.	W	350	350
Dimensions (W x H x D)	mm (in.)	430 x 456 x 420 (16.93 x 17.95 x 16.54)	430 x 456 x 420 (16.93 x 17.95 x 16.54)
Weight, approx.	kg (lbs)	20 (44.15)	20 (44.15)

Ordering Information

PT 70 Dry

PT 70 Dry turbomolecular pump system			
DN 63 ISO-K 230 V, 50 Hz		Part No. 500 846	-
DN 63 ISO-K 115 V, 60 Hz		upon request	-
DN 63 CF 230 V, 50 Hz		-	Part No. 500 001 032
DN 63 CF 115 V, 60 Hz		-	upon request
Switch box		Part No. 200 06 393	Part No. 200 06 393
Mains adapter Schuko/US		Part No. 200 11 119	Part No. 200 11 119
Mains cord for junction box			
EURO 230 V, 50 Hz		Part No. 200 81 091	Part No. 200 81 091
CH 230 V, 50/60 Hz		Part No. 200 81 099	Part No. 200 81 099
UK 230 V, 50/60 Hz		Part No. 200 81 097	Part No. 200 81 097
USA/Japan 230 V, 50/60 Hz		Part No. 200 81 141	Part No. 200 81 141
USA/Japan 115 V, 60 Hz		Part No. 200 81 090	Part No. 200 81 090
Power failure venting valve 230 V, 50/60 Hz		Part No. 174 26	Part No. 174 26
24 V DC mains cord			
3 m		Part No. 800094V0300	Part No. 800094V0300
5 m		Part No. 800094V0500	Part No. 800094V0500
10 m		Part No. 800094V1000	Part No. 800094V1000
20 m		Part No. 800094V2000	Part No. 800094V2000

PT 70 Compact Turbomolecular Pump System



Turbomolecular pump system PT 70 B-Compact (left) and PT 70 F-Compact (right)

The PT 70 Compact turbomolecular pump system is a fully assembled and ready-to-operate high vacuum system designed as a table top unit.

Advantages to the User

- Absolutely oil-free
- Low ultimate pressure free of hydrocarbons (10^{-8} mbar/Torr)
- High effective pumping speed
- Compact and small unit
- Simple operation
- High level of reliability
- Maintenance-friendly design
- Air cooling
- Installation of standard vacuum components in a portable sheet metal frame enclosure

Only PT 70 B-Compact:

- Manual operation
- Pressure measurement as an option via ITR 90 with display

Only PT 70 F-Compact:

- Pressure indication
- Manual or automatic operation
- Operation parameter indication
- Forevacuum pressure measurement optional

The turbomolecular pump system consists of the following principal components:

- TW 70 H hybrid turbomolecular pump system featuring:
 - Integrated frequency converter
 - Integrated air cooling
 - Ceramic ball bearings
 - Grease lubrication
- Pumping speed for nitrogen: 60 l x s^{-1}
- High vacuum connection: DN 63 ISO-K or DN 63 CF
- Integrated splinter guard
- Dual-stage, absolutely oil-free DIVAC 0.8 T diaphragm vacuum pump used as the backing pump with the following specifications:

Pumping speed:
 $0.7 \text{ m}^3 \times \text{h}^{-1}$ (0.41 cfm)

Ultimate pressure:
 $\leq 3 \text{ mbar}$ ($\leq 2.25 \text{ Torr}$)

- All required connection and sealing components are located within the pump system assembly

The pump system is prepared for installation of further components:

- Vacuum gauges
- Venting valve

Typical Applications

- Spectroscopy
- Valve manufacturing
- Beam guidance systems
- Micro balances
- Sputtering and evaporation systems
- Surface physics
- Laboratory pump systems

Scope of Delivery

Included within the delivery of the PT 70 F-Compact is a high vacuum gauge ITR 90 (without display) and 5 m measuring cable.

The pressure readout is effected through the display of the pump system. The 24 V power supply for operating one ITR 90 is provided from the side of the pump system.

Technical Data

PT 70 B-Compact

PT 70 F-Compact

Hybrid turbomolecular pump		TW 70 H	TW 70 H
High vacuum connection	DN	63 ISO-K / 63 CF	63 ISO-K / 63 CF
Pumping speed for N ₂	l x s ⁻¹	60	60
Diaphragm pump		DIVAC 0,8 T	DIVAC 0,8 T
Pumping speed, approx.	m ³ x h ⁻¹ (cfm)	0.7 (0.41)	0.7 (0.41)
Ultimate pressure, approx.	mbar (Torr)	3 (2.25)	3 (2.25)
Attainable ultimate pressure	mbar (Torr)	10 ⁻⁷ (0.75 x 10 ⁻⁷) / 10 ⁻⁸ (0.75 x 10 ⁻⁸)	10 ⁻⁷ (0.75 x 10 ⁻⁷) / 10 ⁻⁸ (0.75 x 10 ⁻⁸)
Run-up time, approx.	min	1.5	1.5
Main supply, 50 Hz	V	230	230
Rated power consumption, approx.	W	240	240
Dimensions (W x H x D)	mm (in.)	255 x 355 x 355 (10.04 x 13.98 x 13.98)	255 x 355 x 355 (10.04 x 13.98 x 13.98)
Weight, approx.	kg (lbs)	14.5 (32.01)	14.5 (32.01)

Ordering Information

PT 70 B-Compact

PT 70 F-Compact

Turbomolecular pump system			
PT 70 B-Compact, without sensor and sensor cable		Part No. 500 002 469	-
DN 63 ISO-K 230 V, 50 Hz		Part No. 500 002 470	-
DN 63 CF 230 V, 50 Hz		-	-
PT 70 F-Compact		-	Part No. 500 002 471
DN 63 ISO-K 230 V, 50 Hz (incl. ITR 90 sensor, DN 25 KF, without display and sensor cable)		-	Part No. 500 002 472
DN 63 CF 230 V, 50 Hz (incl. ITR 90 sensor, DN 40 CF, without display and sensor cable)		-	Part No. 500 002 472
Venting valve, 24 V DC normally open		Part No. 720 53 112	-
normally closed		-	Part No. 720 53 113
ITR 90 sensor, DN 25 KF with display		Part No. 120 91	Part No. 120 91
ITR 90 sensor, DN 40 CF with display		Part No. 120 94	Part No. 120 94
ITR sensor cable, 5 m		Part No. 124 55	Part No. 124 55
TTR 90 foreline sensor, 1/2" O. D. tube		-	Part No. 128 13

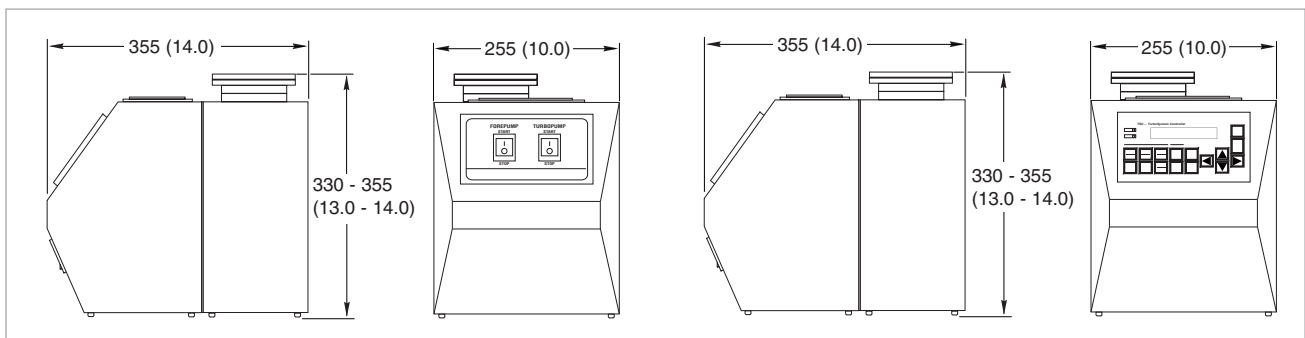

Dimensional drawing for the turbomolecular pump system PT 70 B-Compact (left) and PT 70 F-Compact (right)
Dimensions in brackets () are in inch

PT 300 Dry Turbomolecular Pump System

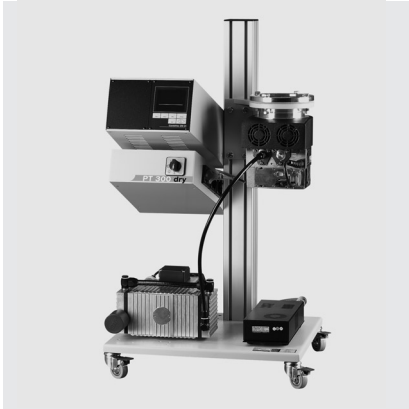

The PT 300 Dry turbomolecular pump system is a fully assembled, ready-to-operate and mobile high vacuum pump system which is based on a column design.

Advantages to the User

- Absolutely oil-free
- Low ultimate pressure free of hydrocarbons (10^{-9} mbar/Torr)
- High effective pumping speed
- Compact, mobile unit
- Simple operation
- High level of reliability
- Maintenance-friendly design
- Installation in any orientation for TW 300 H
- Air cooling
- Installation of standard vacuum components in an open frame with installation column and castors
- Components such as the diaphragm backing pump and turbomolecular pump as well as venting or degassing are controlled via a single rotary switch
- Service-friendly assembly for maintenance without the need to disassemble backing or high vacuum pump
- Pump systems prepared for installation of larger backing pumps
- Additional mains sockets for accessories
- The pump systems are subjected to a full functional test and a leak test before delivery

The turbomolecular pump system consists of the following principal components:

- TW 300 H hybrid turbomolecular pump
- Dual-stage, absolutely oil-free DIVAC 2.5 VT diaphragm vacuum pump used as the backing pump
- Switchbox for driving and interlocking of the two vacuum pumps
- Mobile base plate with column
- All required connection and sealing components are located within the pump system assembly

The pump systems are prepared for installation of further components:

- Vacuum gauges
- Flange heater
- Venting valve

Typical Applications

- Spectroscopy
- Valve manufacturing
- Beam guidance systems
- Micro balances
- Sputtering and evaporation systems
- Surface physics
- Laboratory pump systems

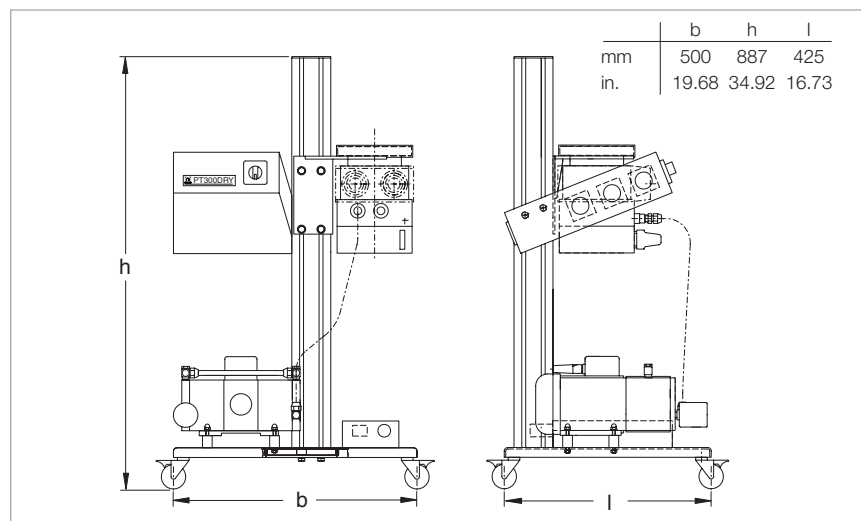

Dimensional drawing for the PT 300 Dry turbo molecular pump system

Technical Data

PT 300 Dry

Hybrid turbomolecular pump		TW 300 H	TW 300 H
High vacuum connection	DN	100 ISO-K	100 CF
Pumping speed for N ₂	l x s ⁻¹	240	240
Diaphragm pump		DIVAC 2.5 VT	DIVAC 2.5 VT
Pumping speed, approx.	m ³ x h ⁻¹ (cfm)	2.5 (1.5)	2.5 (1.5)
Ultimate pressure, approx.	mbar (Torr)	3 (2.25)	3 (2.25)
Attainable ultimate pressure	mbar (Torr)	10 ⁻⁷ (0.75 x 10 ⁻⁷)	10 ⁻⁹ (0.75 x 10 ⁻⁹)
Main supply, 50/60 Hz	V	230 / 115	230 / 115
Rated power consumption, approx.	W	600	600
Dimensions (W x H x D)	mm (in.)	500 x 887 x 425 (19.68 x 34.92 x 16.73)	500 x 887 x 425 (19.68 x 34.92 x 16.73)
Weight, approx.	kg (lbs)	44 (97.13)	44 (97.13)

Ordering Information

PT 300 Dry

PT 300 Dry turbomolecular pump system			
DN 100 ISO-K 230 V, 50 Hz		Part No. 500 687	-
DN 100 ISO-K 115 V, 60 Hz		Part No. 500 693	-
DN 100 CF 230 V, 50 Hz		-	Part No. 500 688
DN 100 CF 115 V, 60 Hz		-	Part No. 500 694
Switch box		Part No. 200 06 393	Part No. 200 06 393
Mains adapter Schuko/US		Part No. 200 11 119	Part No. 200 11 119
Mains cord for junction box			
EURO 230 V, 50 Hz		Part No. 200 81 091	Part No. 200 81 091
CH 230 V, 50/60 Hz		Part No. 200 81 099	Part No. 200 81 099
UK 230 V, 50/60 Hz		Part No. 200 81 097	Part No. 200 81 097
USA/Japan 230 V, 50/60 Hz		Part No. 200 81 141	Part No. 200 81 141
USA/Japan 115 V, 60 Hz		Part No. 200 81 090	Part No. 200 81 090
Power failure airing valve 230 V, 50/60 Hz		Part No. 174 26	Part No. 174 26
Flange heater for flange DN 100 CF, 230 V		Part No. 854 27	Part No. 854 27
24 V DC mains cord			
3 m		Part No. 800094V0300	Part No. 800094V0300
5 m		Part No. 800094V0500	Part No. 800094V0500
10 m		Part No. 800094V1000	Part No. 800094V1000
20 m		Part No. 800094V2000	Part No. 800094V2000

PT 301 Dry Turbomolecular Pump System



The PT 301 Dry turbomolecular pump system is a fully assembled and ready-to-operate high vacuum system designed as a table top unit.

Advantages to the User

- Absolutely oil-free
- Low ultimate pressure free of hydrocarbons (10^{-9} mbar/Torr)
- High effective pumping speed
- Compact, small unit
- Simple operation
- High level of reliability
- Maintenance-friendly design
- Air cooling
- Installation of standard vacuum components in an open frame
- Components such as the diaphragm backing pump and turbomolecular pump are controlled via switches
- Service-friendly assembly for maintenance without the need to disassemble backing or high vacuum pump
- The high vacuum pump can be removed (installation in any orientation)
- The pump systems are subjected to a full functional test and a leak test before delivery

The turbomolecular pump system consists of the following principal components:

- TW 300 H hybrid turbomolecular pump system
- TURBO.POWER 300 power supply
- Dual-stage, absolutely oil-free DIVAC 2.5 VT diaphragm vacuum pump used as the backing pump
- All required connection and sealing components are located within the pump system assembly

The pump systems are prepared for installation of further components:

- Vacuum gauges
- Venting valve / Power failure venting valve
- Junction box

Typical Applications

- Spectroscopy
- Valve manufacturing
- Beam guidance systems
- Micro balances
- Sputtering and evaporation systems
- Surface physics
- Laboratory pump systems

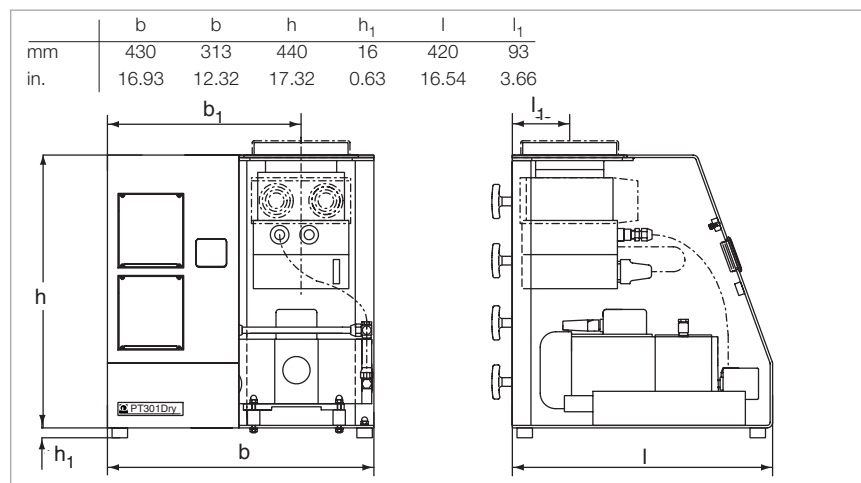

Dimensional drawing for the PT 301 Dry turbomolecular pump system

Technical Data

PT 301 Dry

Hybrid turbomolecular pump		TW 300 H	TW 300 H
High vacuum connection	DN	100 ISO-K	100 CF
Pumping speed for N ₂	l x s ⁻¹	240	240
Diaphragm pump		DIVAC 2.5 VT	DIVAC 2.5 VT
Pumping speed, approx.	m ³ x h ⁻¹ (cfm)	2.5 (1.5)	2.5 (1.5)
Ultimate pressure, approx.	mbar (Torr)	3 (2.25)	3 (2.25)
Attainable ultimate pressure	mbar (Torr)	10 ⁻⁷ (0.75 x 10 ⁻⁷)	10 ⁻⁹ (0.75 x 10 ⁻⁹)
Main supply, 50/60 Hz	V	230 / 115	230 / 115
Rated power consumption, approx.	W	600	600
Dimensions (W x H x D)	mm (in.)	430 x 456 x 420 (16.93 x 17.95 x 16.54)	430 x 456 x 420 (16.93 x 17.95 x 16.54)
Weight, approx.	kg (lbs)	31 (68.43)	31 (68.43)

Ordering Information

PT 301 Dry

PT 301 Dry turbomolecular pump system			
DN 100 ISO-K 230 V, 50 Hz		Part No. 500 685	-
DN 100 ISO-K 115 V, 60 Hz		Part No. 500 691	-
DN 100 CF 230 V, 50 Hz		-	Part No. 500 686
DN 100 CF 115 V, 60 Hz		-	Part No. 500 692
Switch box		Part No. 200 06 393	Part No. 200 06 393
Mains adapter Schuko/US		Part No. 200 11 119	Part No. 200 11 119
Mains cord for junction box			
EURO 230 V, 50 Hz		Part No. 200 81 091	Part No. 200 81 091
CH 230 V, 50/60 Hz		Part No. 200 81 099	Part No. 200 81 099
UK 230 V, 50/60 Hz		Part No. 200 81 097	Part No. 200 81 097
USA/Japan 230 V, 50/60 Hz		Part No. 200 81 141	Part No. 200 81 141
USA/Japan 115 V, 60 Hz		Part No. 200 81 090	Part No. 200 81 090
Power failure airing valve 230 V, 50/60 Hz		Part No. 174 26	Part No. 174 26
24 V DC mains cord			
3 m		Part No. 800094V0300	Part No. 800094V0300
5 m		Part No. 800094V0500	Part No. 800094V0500
10 m		Part No. 800094V1000	Part No. 800094V1000
20 m		Part No. 800094V2000	Part No. 800094V2000

CS Calibration Systems

The requirements imposed on vacuum engineering with regard to accuracy of the measurements, reproducibility and unambiguity of the determined vacuum pressures have increased significantly over the last years.

Routine calibrations of vacuum gauges are an important component of quality assurance schemes. The calibration systems from Oerlikon Leybold Vacuum put the customer in a position to check and recalibrate on his own the specified and necessary accuracy of his vacuum gauges.

Calibration systems are available for this purpose which cover a calibration range from 1000 mbar to 1×10^{-7} mbar (750 to 0.75×10^{-7} Torr).

Each system is equipped with several certified reference pressure sensors (transmitter standards), which each cover a part of the specified range of calibration pressures. In the pump system, turbomolecular pumps with TRIVAC rotary vane or DIVAC diaphragm pumps are used. A variable leak valve is used to admit the gas into the calibration chamber. In the case of the calibration system CS7, the gas inlet line is, moreover, equipped with it's own pump system.

The CS7 is equipped with a heater for the vacuum chamber, for the purpose of attaining lower chamber pressures more rapidly. The temperature of the heating collars can be controlled whereby the maximum degassing temperature will depend on the components installed (flanges, pressure sensors, valves).

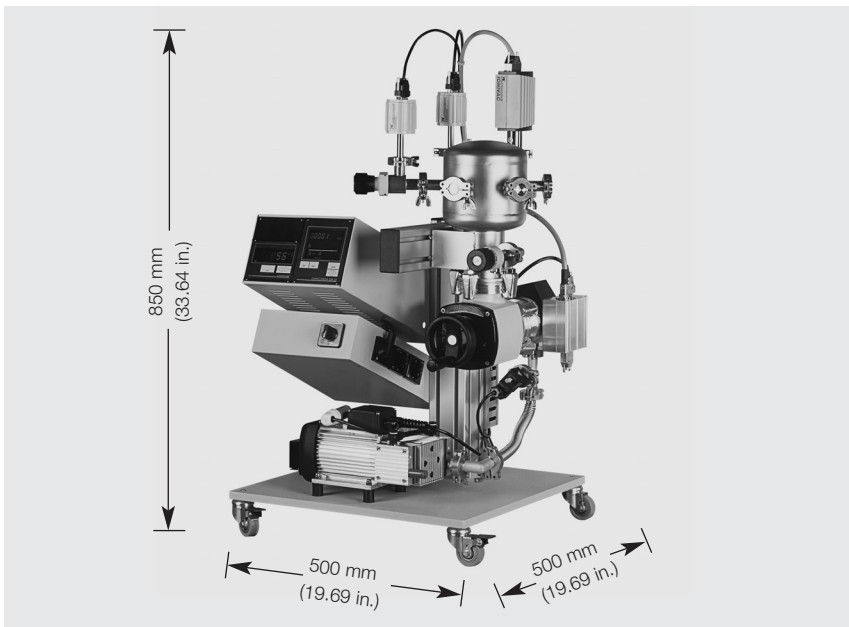

CS3 calibration system

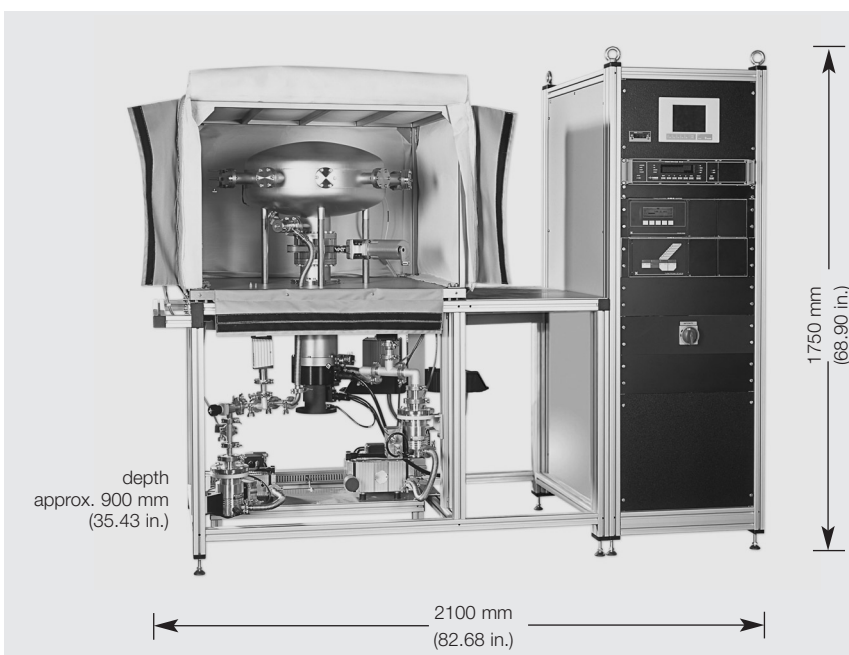

CS7 calibration system

Advantages to the User

- Vacuum gauges and measurement systems of any make may be calibrated
- Designed in accordance with DIN 28 418/ISO/DIS 3567
- Transfer standards with PTB-, DKD- or factory certificate
- Easier DIN/ISO 9000 approval
- Reliable and reproducible measurements
- Quick start-up
- Measurement system free of hydrocarbons when using dry compressing vacuum pumps
- Simple operation
- CE approval

Technical Data

Calibration System

		CS3	CS7
Calibration range	mbar (Torr)	1000 to 1×10^{-3} (750 to 0.75×10^{-3})	1000 to 1×10^{-7} (750 to 0.75×10^{-7})
Pressure measurement range	mbar (Torr)	1000 to 2×10^{-6} (750 to 1.5×10^{-6})	1000 to 2×10^{-9} (750 to 1.5×10^{-9})
Vacuum chamber connections (in brackets: quantity available on the side of the customer's system)		5 (3) x DN 16 KF 1 (0) x DN 25 KF	6 (3) x DN 16 CF 6 (4) x DN 40 CF
Admitting gas		via variable leak valve	via variable leak valve
Extra pump system for admitting gas		no	yes
Heater for the vacuum chamber		no	yes

Application examples:

Which pressure sensors may be calibrated with which system?

Typ of Sensor

Calibration System

	CS3	CS7
Diaphragm sensors		
BOURDONVAC	■	■
Capsule vacuum gauges	■	■
DIAVAC DV 1000	■	■
DI 200, DI 2000	■	■
CTR 90, CTR 91, CTR 100 (1000 - 1 Torr full scale)	■	■
CTR 91 (0.1 Torr full scale)		■
THERMOVAC sensors		
TR 301, TR 306	■	■
TR 211, TR 216, TTR 211, TTR 216, TTR 90, TTR 91, TTR 96, TTR 100	■	■
VISCOVAC sensor (spinning rotor viscosity gauge)		
VK 201		■
PENNINGVAC sensors		
PR 25, PR 26, PR 27, PR 35, PR 36, PR 37, PTR 90, PTR 225		■
IONIVAC sensors		
ITR 90, ITR 100, ITR 200		■
IE 414, IE 514		■

Ordering Information

Calibration System

	CS3	CS7
Ordering information and options	upon request	upon request

Delayed Venting Unit



Delayed venting unit

The present operating condition is showed by different displays and controls:

- "Delay Time"
Displays the entered delay time (when mains powered) and the delay time counting to 0 (in case of power failure).
- "Venting Time"
Displays the entered venting time (when mains powered and during delay time in case of power failure) and, after elapsed delay time, the venting time counting to 0.
- LED display for "battery status"
 - "loading"
battery is being charged
 - "empty"
battery is flat or defective
 - "ok"
battery is in working order
- LED "POWER"
the unit is mains powered

The delayed venting unit serves the purpose of venting vacuum systems with a delay in that it bridges power failures.

The unit is equipped with rechargeable batteries. Any unwanted venting of the turbomolecular pump can thus be reliably prevented in the event of short power blackouts.

Both normally open valves (power failure venting valves) and normally closed valves (venting valves) may be connected.

The unit is equally suited for benchtop use and rack mounting.

Advantages to the User

- Adjustable venting time for power failure venting valve:
0 to 999 seconds
- Adjustable venting time for venting valve:
0 to 999 seconds
- Automatic driving of failure venting valve and venting valve in case of short power failures
- Manual venting
- Remote controlled venting

Technical Data

Delayed Venting Unit

Mains connection		Mains socket
Power supply	V AC / Hz	100 - 240 / 50/60
Output	V DC / mA	24 - 26.4 / 400 max.
Rechargeable lead battery	V / Ah	2 x 12 / 1.3
Rated battery service life, approx.	years	5 (depending on utilization)
Max. number of venting cycles with fully charged battery		4 times after each other
Controls		Foil key pad
Display		numerical, 2 x 3 digits, 4x LED
Delay time	s	0 - 999, adjustable
Venting time	s	0 - 999, adjustable
Dimensions (W x H x D)	mm (in.)	106.5 x 128.5 x 220 (4.19 x 5.06 x 8.66)
Housing		1/4 19", for rack mounting or as benchtop unit
Weight, approx.	kg (lbs)	2.5 (5.58)

Ordering Information

Delayed Venting Unit

Delayed venting unit	Part No. 500 441
Power failure airing valve, DN 10 KF, 24 V DC	Part No. 174 46
Mains cord with German style mains plug (Schuko) with US style mains plug	Part No. 200 27 549 Part No. 200 27 550

Adsorption Traps with Aluminium Oxide Insert

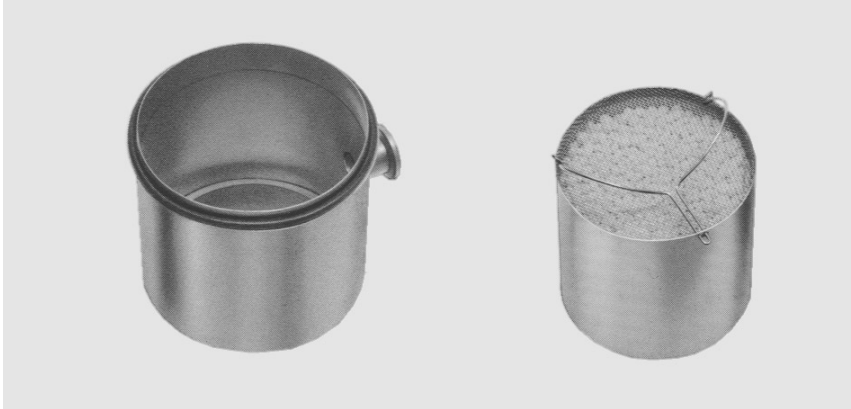

Adsorption trap (left) and insert (right)

Adsorption traps are installed in all those cases where an oil-free vacuum is to be produced with oil-sealed vacuum pumps.

Advantages to the User

- Backstreaming of oil is reduced by 99 %
- Longer service life
- High conductance
- Filling can be easily exchanged
- Improvement in the ultimate pressure attained by backing pumps by one order of magnitude
- Stainless steel housing and insert
- NBR seal

Typical Applications

- Product of an oil-free vacuum

Supplied Equipment

- Complete with insert
- Without adsorbent

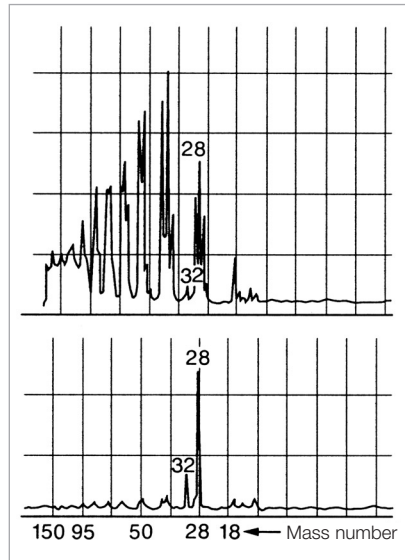

Residual gas spectrum; top ahead of a rotary vacuum pump, bottom ahead of a rotary vacuum pump with adsorption trap

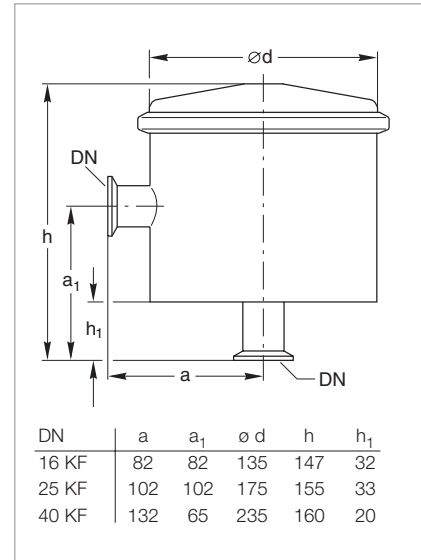

Dimensional drawing for the adsorption traps

Technical Data

		Adsorption Trap		
		16 KF	25 KF	40 KF
Conductance at 10 ⁻² mbar (Torr)	l x s (l x sec)	4	6	12
Service live with Al oxide	Months	3	3	3
Al oxide filling	l (qts)	0.5 (0.53)	1.0 (1.06)	2.0 (2.1)
Weight, approx.	kg (lbs)	1.3 (2.9)	1.3 (2.9)	4.0 (8.8)

Ordering Information

		Adsorption Trap		
		16 KF	25 KF	40 KF
Adsorption trap		Part No. 854 14	Part No. 854 15	Part No. 854 16
Activated aluminum oxide in tin 1.6 l (approx. 1.2 kg (2.65 lbs))		Part No. 854 10	Part No. 854 10	Part No. 854 10

Only available for purchase in North and South America

Dry Oil Free HV Pump System BMH70 Dry



Standard Equipment

- Portable HV station for TW 70 H and DIVAC 0.8 T
- 60 l/s, pumping speed for N₂, ultimate of 5×10^{-9} Torr
- Automated one-button operation for full featured model
- Power supply for operation of pumps, gauges and valves
- Display of TW 70 H Turbo operation parameters include:
 - Rotation frequency (Hz)
 - Rotation speed (rpm)
 - Bearing temperature (deg C)
 - Motor current (amps)
 - Motor temperature (deg C)
 - Supply voltage (V)
 - Heat sink temperature (deg C)
 - Cumulative operating time (hours)
- Standard air cooling
- Small footprint of 14" x 10" x 14" (W x H x D)
- 32 lbs
- Full-featured and basic versions available
- Optional 230/1/50/60 operation

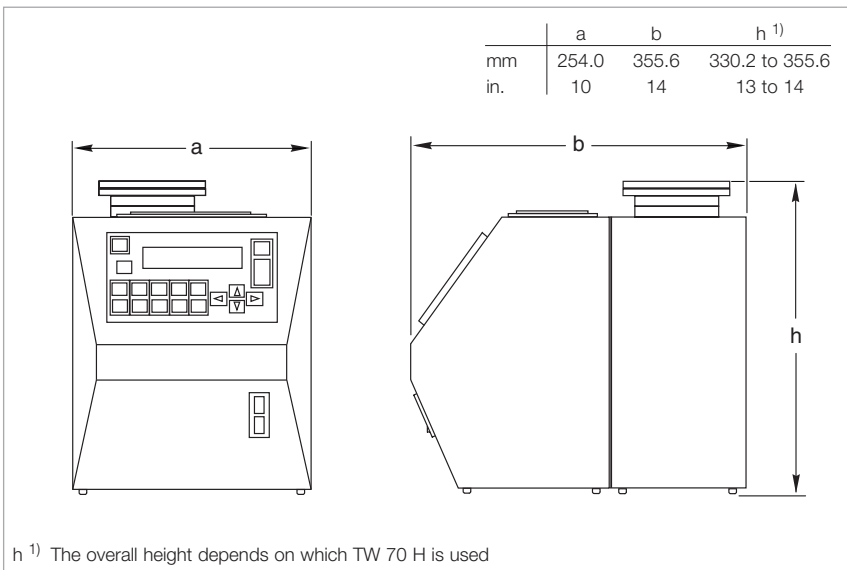

Dimensional drawing for the dry oil free HV pump system BMH70 Dry

Technical Data

BMH70 Dry

	Basic Version	Full-featured Version
Integrated gauge display	No	Yes
Standard inlet sensor	(optional, see below)	Power ITR 90 inlet sensor (atm - 10^{-10} Torr) with display on system controller
Optional inlet sensor	Power ITR 90 inlet sensor (atm - 10^{-10} Torr) with integral LCD display	N/A
Optional foreline sensor	N/A	Power TTR 90 sensor (atm - 5×10^{-4} Torr) with display on system controller
System control	Manual	Automatic control (one button) or manual
Vent valve control	Vent valve control ¹⁾	Vent valve control ¹⁾
TW main status display	Start, Accel., Norm. Op., Decel., Stop	Start, Accel., Norm. Op., Decel., Stop
TW operating parameters display	Speed, Temps, Current Draw, etc.	Speed, Temps, Current Draw, etc.

Ordering Information

BMH70 Dry

	Basic Version ^{2), 3)}	Full-featured Version ^{2), 4)}
BMH70 Dry ⁵⁾ with inlet flange DN 63 CF with inlet flange DN 63 ISO-K	Part No. 180000V2000 Part No. 180000V1000	Part No. 180001V2400 Part No. 180001V1200

¹⁾ The vent valve is optional on a basic and a full-featured system

²⁾ An ITR 90 sensor shipped with a BMH70 Dry system will have a flange compatible with the turbomolecular pumps flange type unless otherwise requested. (i.e., DN 63 CF turbomolecular pump = CF 40-flanged ITR 90; DN 63 ISO-K turbomolecular pump = KF 25-flanged ITR 90)

³⁾ An optional ITR 90 sensor when ordered with a basic BMH70 Dry system will include an integrated display on the sensor for the pressure readout

⁴⁾ The standard ITR 90 sensor shipped with the full-featured BMH70 Dry system does not include an integrated display on the sensor for the pressure readout. (It is available as an option)

⁵⁾ Many other standard part numbers are available for other versions of both the BMH70 Dry Basic and Full-Featured systems which include optional components such as venting valves, foreline sensors, etc. Refer to the current North American Price List or contact the factory for further information.

Only available for purchase in North and South America

PT-FLEX Dry Turbomolecular Pump System



PT-FLEX pumping systems provide unique flexibility, allowing the user to define the optimum combination of performance and price.

PT-FLEX pump systems are offered with three sizes Compound Turbo-molecular pumps, three sizes dry Scroll backing pumps, a basic or full-featured system controller and the ability to incorporate and control multiple valves, vacuum gauges, flange heaters and other peripheral equipment.

PT-FLEX systems can be specially configured with classic turbo pumps and rotary vane forevacuum pumps. Please consult Oerlikon Leybold Vacuum for details.

Advantages to the User

- Oil free high vacuum
- Compact, mobile
- Air cooled
- Adjustable height
- Fully assembled and tested

Configuration and Capabilities

- Three sizes turbo pump
- Three sizes dry scroll forevacuum pump
- Manual or powered height adjustment
- Ability to power and control multiple peripheral devices (sold separately)
- Basic or full-featured TSC system controller
- Allows mounting of one or two rack gauge controllers

PT-FLEX with BASIC Controller

- Mains ON/OFF
- Mains switch activated 110 V AC output for use with vent valve or gauge controller
- Start / Stop switch for both pumps
- Manual control and power for
 - Pumps
 - Vent valves
 - Vacuum isolation valves
 - Flange heater
- Provides additional 110 V AC and 24 V DC outputs to power additional peripheral devices
- Vacuum Ion Gauge degas function for gauge model ITR 90
- Turbo operation indicator

PT-FLEX with TSC Controller

(see separate catalog page for in-depth description of features and capabilities)

- One button auto system control
- Monitors and displays all turbo pump operating and diagnostic parameters
- Acts as display for up to 3 "smart" vacuum gauge sensors
- All features of PT-Flex BASIC controller
- Additional power and control capabilities for peripheral equipment

Technical Data

PT-FLEX

Turbomolecular pump High vacuum connection	DN	TURBOVAC TW 70 63 ISO-K 63 CF	TURBOVAC TW 250 S 100 ISO-K 100 CF	TURBOVAC TW 300 100 ISO-K 100 CF 160 ISO-K
Backing pumps		SCROLLVAC SC 5 D	SCROLLVAC SC 5 D SCROLLVAC SC 15 D	SCROLLVAC SC 5 D SCROLLVAC SC 15 D
Cooling		Air	Air (water option)	Air (water option)
Max. current requirements (dependent on forepump)	V AC Phase Hz A	115 1 50/60 15	115 1 50/60 15	115 1 50/60 15
Controller		<p>TSC Turbo System Controller AUTO operation with gauge selection or Manual TW monitoring status Gauge sensor display with smart gauge selection</p> <p>Accessory Control Inlet, foreline and roughing valve Vent/purge valve Flange heater (CF flange only) Ion sensor degas</p> <p>Basic System Controller Manual Start/Stop operation</p> <p>Accessory Control Vacuum valve Vent valve Flange heater (CF flange only) Ion sensor degas Column height adjustment (option)</p>		

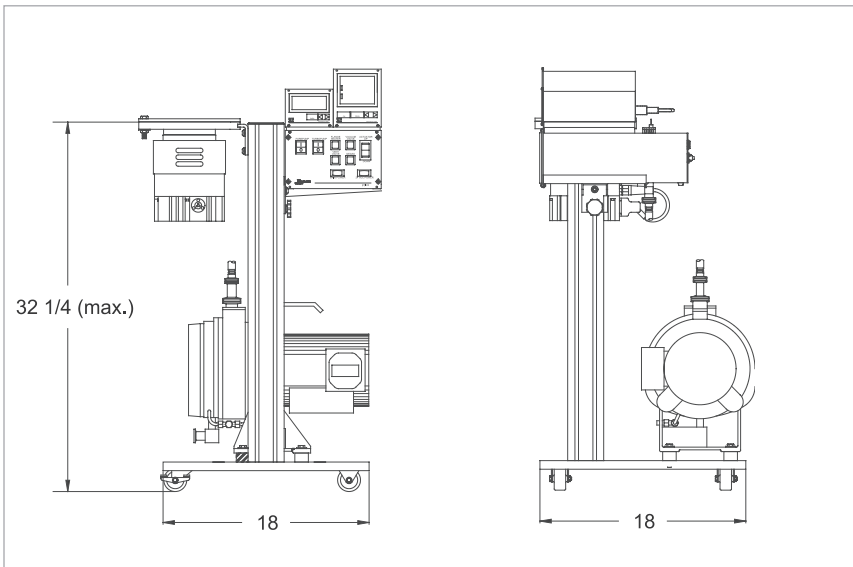

Dimensional drawing for the PT-Flex (manual post)

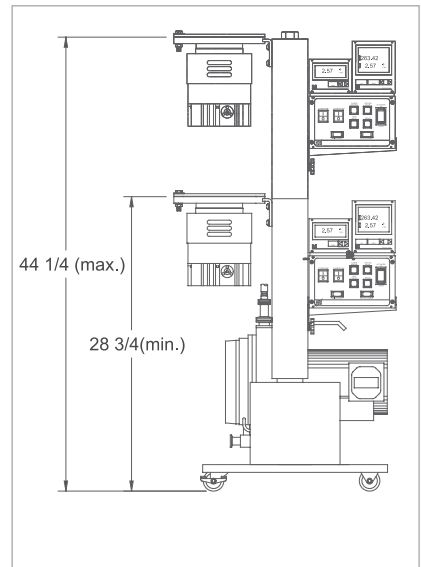

Dimensional drawing (front view) for the PT-Flex (powered support)

Ordering Information

PT-Flex

Base number

Manual controls

- manual height adjustment
- electric height adjustment

Automated controls

- manual height adjustment

Turbomolecular pump

Not used

TW 70 with 63 ISO-K inlet

TW 70 with 63 CF inlet

TW 300 with 100 ISO-K inlet

TW 300 with 160 ISO-K inlet

TW 300 with 100 CF inlet

TW 250 S with 100 ISO-K inlet

TW 250 S with 100 CF inlet

Dry scroll pump

Not used

SC 5 D

Reserved for future use

SC 15 D (TW 250 S and TW 300 only)

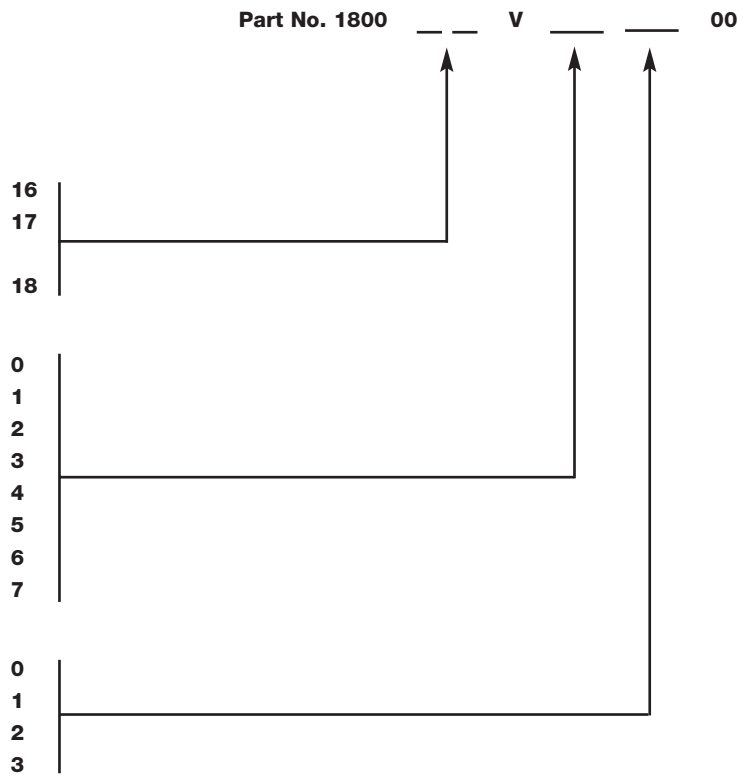

Only available for purchase in North and South America

TSC-TurboSystem Controller

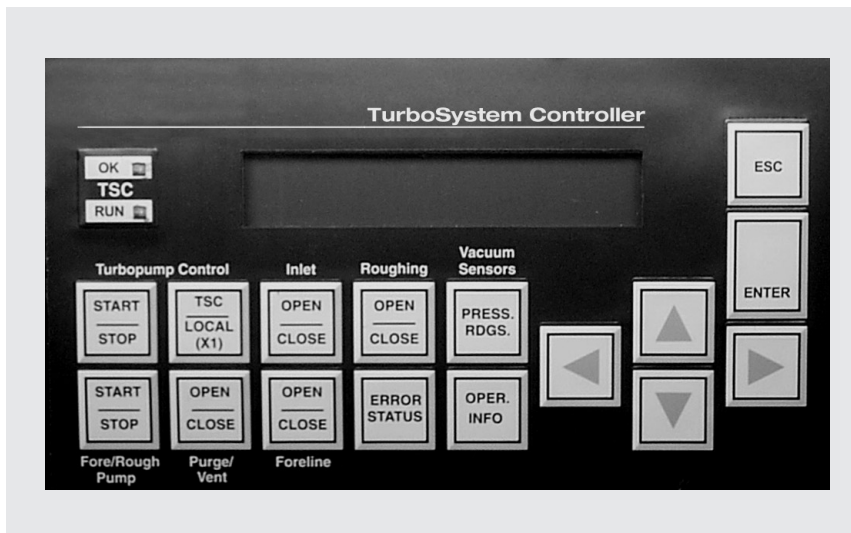

The TSC controller will:

- Display all relevant turbo information:
 - Connected pump model
 - Rotation frequency (Hz)
 - Rotation speed (rpm)
 - Bearing temperature (°C)
 - Motor current (Amps)
 - Motor temperature (°C)
 - Supply voltage (V)
 - Heatsink temperature (°C)
 - Cumulative operating time (hours)
- Power the turbomolecular pump
- Power the fore/rough pump (up to TRIVAC D 16 B or ECODRY M 15, 115 V single phase)
- Power and display up to three of any manufacturer's smart gauges (must have 0 - 10 V or 4 - 20 mA output capability)
- Provide degas capability for a hot-cathode ion gauge sensor
- Power up to three system valves (electropneumatic with 24 V DC coils; electromagnetic valves on request) – typically an inlet valve, foreline valve and roughing valve
- Power a turbomolecular pump vent or purge/vent valve
- Power an inlet flange heater (CF flanged pumps only)
- Control the turbomolecular pump, fore/rough pump and all valves

Technical Data

TSC - TurboSystem Controller

For operating turbomolecular pump TSC-S TurboSystem Controller TSC-L TurboSystem Controller	TURBOVAC TW 300 / TW 70 H -	- TURBOVAC TW 700
---	--------------------------------	----------------------

Ordering Information

TSC - TurboSystem Controller

TSC - TurboSystem Controller 110 V, RS 485 C TSC-S TSC-L 110 V, RS 232 C TSC-S TSC-L	Part No. 899 287 - Part No. 899 289 -	- Part No. 899 288 - Part No. 899 290
Venting valve 24 V DC, normally open 24 V DC, normally closed	Part No. 899 813 Part No. 899 814	Part No. 899 813 Part No. 899 814

Note:

All controllers include:
15 ft. (5 m) long cables between TSC controller and turbomolecular pump (power & communication)
6 ft. (2 m) power cord
Mating connectors for all accessorizing outlets
Operating manual, electrical schematic, and spare parts list

Only available for purchase in North and South America

TPC-TurboPump Controller

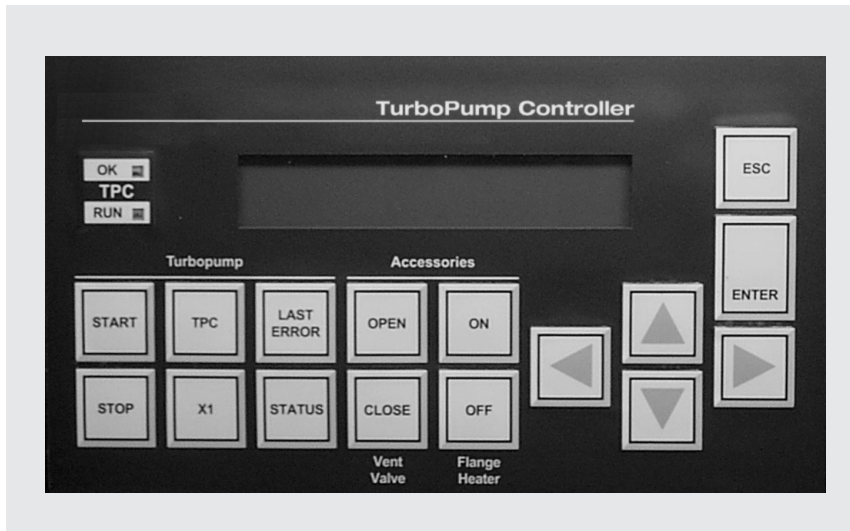

The TPC controller will:

- Display all relevant turbo information:
 - Connected pump model
 - Rotation frequency (Hz)
 - Rotation speed (rpm)
 - Bearing temperature (°C)
 - Motor current (Amps)
 - Motor temperature (°C)
 - Supply voltage (V)
 - Heatsink temperature (°C)
 - Cumulative operating time (hours)
- Power the turbomolecular pump
- Power a turbomolecular pump vent or purge/vent valve
- Power an inlet flange heater (CF flanged pumps only)
- Control the turbomolecular pump, flange heater and purge/vent valve

Technical Data

TPC - TurboPump Controller

For operating turbomolecular pump TPC-S TurboPump Controller	TURBOVAC TW 300 TURBOVAC TW 70 H	-	-
TPC-L TurboPump Controller	-	TURBOVAC TW 700	-
TPC-1600 TurboPump Controller	-	-	TURBOVAC T 1600 TURBOVAC TW 1600

Ordering Information

TPC - TurboPump Controller

TPC - TurboPump Controller 110 V, RS 485 C TPC-S	Part No. 899 281	-	-
TPC-L	-	Part No. 899 282	-
110 V, RS 232 C TPC-S	Part No. 899 283	-	-
TPC-L	-	Part No. 899 284	-
115 V, RS 485 C TPC-1600	-	-	Part No. 899 285
115 V, RS 232 C TPC-1600	-	-	Part No. 899 286
230 V, RS 485 C TPC-1600	-	-	Part No. 899 295
230 V, RS 232 C TPC-1600	-	-	Part No. 899 296
Venting valve 24 V DC, normally open	Part No. 899 813	Part No. 899 813	Part No. 899 813
24 V DC, normally closed	Part No. 899 814	Part No. 899 814	Part No. 899 813

Note:

All controllers include:

15 ft. (5 m) long cables between TSC controller and turbomolecular pump (power & communication)

6 ft. (2 m) power cord

Mating connectors for all accessory, outlets

Operating manual, electrical schematic, and spare parts list

Sales and Service

Germany

Oerlikon
Leybold Vacuum GmbH
Bonner Strasse 498
D-50968 Cologne
Phone: +49-(0)221-347 1234
Fax: +49-(0)221-347 1245
sales.vacuum@oerlikon.com
www.oerlikon.com

Oerlikon
Leybold Vacuum GmbH
Sales Area North/Northeast
Branch Office Berlin
Buschkrugallee 33
1. Obergeschoss
D-12359 Berlin
Phone: +49-(0)30-435 609 0
Fax: +49-(0)30-435 609 10
sales.vacuum.bn@oerlikon.com

Oerlikon
Leybold Vacuum GmbH
Sales Area South/Southwest
Branch Office Munich
Sendlinger Strasse 7
D-80331 Munich
Phone: +49-(0)89-357 33 9-10
Fax: +49-(0)89-357 33 9-33
sales.vacuum.mn@oerlikon.com
service.vacuum.mn@oerlikon.com

Oerlikon
Leybold Vacuum GmbH
Sales Area West & Benelux
Branch Office Cologne
Bonner Strasse 498
D-50968 Cologne
Phone: +49-(0)221-347 1270
Fax: +49-(0)221-347 1291
sales.vacuum.kn@oerlikon.com

Oerlikon
Leybold Vacuum GmbH
Service Competence Center
Emil-Hoffmann-Strasse 43
D-50996 Cologne-Suerth
Phone: +49-(0)221-347 1439
Fax: +49-(0)221-347 1945
service.vacuum.kn@oerlikon.com

Oerlikon
Leybold Vacuum GmbH
Mobil Customer Service
Emil-Hoffmann-Strasse 43
D-50996 Cologne-Suerth
Phone: +49-(0)221-347 1765
Fax: +49-(0)221-347 1944
service.vacuum.kn@oerlikon.com

Oerlikon
Leybold Vacuum GmbH
Dresden
Zur Wetterwarte 50, Haus 304
D-01109 Dresden
Service:
Phone: +49-(0)351-88 55 00
Fax: +49-(0)351-88 55 041
info.vacuum.dr@oerlikon.com

Oerlikon
Leybold Vacuum USA Inc.
5700 Mellon Road
USA-Export, PA 15632
Phone: +1-724-327-5700
Fax: +1-724-325-3577
info.vacuum.ex@oerlikon.com

Europe

Belgium
Oerlikon
Leybold Vacuum Nederland B.V.
Belgisch bijkantoor
Leuvensesteenweg 542-9A
B-1930 Zaventem
Sales:
Phone: +32-2-711 00 83
Fax: +32-2-720 83 38
sales.vacuum.zv@oerlikon.com
Service:
Phone: +32-2-711 00 82
Fax: +32-2-720 83 38
service.vacuum.zv@oerlikon.com

France
Oerlikon
Leybold Vacuum France S.A.
7, Avenue du Québec
Z.A. Courtaboeuf 1 - B.P. 42
F-91942 Courtaboeuf Cedex
Sales and Service:
Phone: +33-1-69 82 48 00
Fax: +33-1-69 07 57 38
sales.vacuum.or@oerlikon.com

Oerlikon
Leybold Vacuum France S.A.
Valence Factory
640, Rue A. Bergès - B.P. 107
F-26501 Bourg-lès-Valence Cedex
Phone: +33-4-75 82 33 00
Fax: +33-4-75 82 92 69
info.vacuum.vc@oerlikon.com

Great Britain
Oerlikon
Leybold Vacuum UK Ltd.
Unit 2
Silverglade Business Park
Leatherhead Road
UK-Chessington, Surrey KT9 2QL
Sales:
Phone: +44-13-7273 7300
Fax: +44-13-7273 7301
sales.vacuum.ln@oerlikon.com
Service:
Phone: +44-20-8971 7030
Fax: +44-20-8971 7003
service.vacuum.ln@oerlikon.com

Italy
Oerlikon
Leybold Vacuum Italia S.p.A.
8, Via Trasimeno
I-20128 Milano
Sales:
Phone: +39-02-27 22 31
Fax: +39-02-27 20 96 41
sales.vacuum.mi@oerlikon.com
Service:
Phone: +39-02-27 22 31
Fax: +39-02-27 22 32 17
service.vacuum.mi@oerlikon.com

Oerlikon
Leybold Vacuum Italia S.p.A.
Field Service Base
Z.I. Le Capanne
I-05021 Acquasparta (TR)
Phone: +39-0744-93 03 93
Fax: +39-0744-94 42 87
service.vacuum.mi@oerlikon.com

Netherlands
Oerlikon
Leybold Vacuum Nederland B.V.
Proostwetering 24N
NL-3543 AE Utrecht
Sales and Service:
Phone: +31-(30) 242 6330
Fax: +31-(30) 242 6331
sales.vacuum.ut@oerlikon.com
service.vacuum.ut@oerlikon.com

Spain
Oerlikon
Leybold Vacuum Spain, S.A.
C/. Huelva, 7
E-08940 Cornellà de Llobregat
(Barcelona)
Sales:
Phone: +34-93-666 46 16
Fax: +34-93-666 43 70
sales.vacuum.ba@oerlikon.com
Service:
Phone: +34-93-666 49 51
Fax: +34-93-685 40 10
service.vacuum.ba@oerlikon.com

Sweden
Oerlikon
Leybold Vacuum Scandinavia AB
Box 9084
SE-40092 Göteborg
Sales and Service:
Phone: +46-31-68 84 70
Fax: +46-31-68 39 39
info.vacuum.gt@oerlikon.com
Visiting/delivery address:
Datavägen 57B
SE-43632 Askim

Switzerland
Oerlikon
Leybold Vacuum Schweiz AG
Leutschenbachstrasse 55
CH-8050 Zürich
Sales:
Phone: +41-044-308 40 50
Fax: +41-044-302 43 73
sales.vacuum.zh@oerlikon.com
Service:
Phone: +41-044-308 40 62
Fax: +41-044-308 40 60
service.vacuum.zh@oerlikon.com

America

USA
Oerlikon
Leybold Vacuum USA Inc.
5700 Mellon Road
USA-Export, PA 15632
Phone: +1-724-327-5700
Fax: +1-724-325-3577
info.vacuum.ex@oerlikon.com

Sales:
Eastern & Central time zones
Phone: +1-724-327-5700
Fax: +1-724-333-1217
Pacific, Mountain, Alaskan & Hawaiian time zones
Phone: +1-480-752-9191
Fax: +1-480-752-9494
Service:
Phone: +1-724-327-5700
Fax: +1-724-325-3577

Oerlikon
Leybold Vacuum GmbH
Bonner Strasse 498
D-50968 Cologne
Phone: +49-(0)221-347 0
Fax: +49-(0)221-347 1250
info.vacuum.ex@oerlikon.com

Asia

P.R. China
Oerlikon
Leybold Vacuum (Tianjin) International Trade Co. Ltd.
Beichen Economic
Development Area (BEDA),
Shanghai Road
Tianjin 300400
China
Sales and Service:
Phone: +86-22-2697 0808
Fax: +86-22-2697 4061
Fax: +86-22-2697 2017
sales.vacuum.tj@oerlikon.com
service.vacuum.tj@oerlikon.com

Oerlikon
Leybold Vacuum (Tianjin) Co. Ltd.
Beichen Economic
Development Area (BEDA),
Shanghai Road
Tianjin 300400
China
Sales and Service:
Phone: +86-22-2697 0808
Fax: +86-22-2697 4061
Fax: +86-22-2697 2017
info.vacuum.tj@oerlikon.com
service.vacuum.tj@oerlikon.com

Oerlikon
Leybold Vacuum (Tianjin) International Trade Co. Ltd.
Shanghai Branch:
Add: No.33
76 Futedong San Rd.
Waigaoqiao FTZ
Shanghai 200131
China
Sales and Service:
Phone: +86-21-5064-4666
Fax: +86-21-5064-4668
info.vacuum.sh@oerlikon.com
service.vacuum.tj@oerlikon.com

Oerlikon
Leybold Vacuum (Tianjin) International Trade Co. Ltd.
Guangzhou Office and
Service Center
1st F, Main Building
Science City Plaza,
No.111 Science Revenue,
Guangzhou Science City
(GZSC) 510663, Guangzhou,
China
Sales:
Phone: +86-20-8723-7873
Phone: +86-20-8723-7597
Fax: +86-20-8723-7875
info.vacuum.gz@oerlikon.com
service.vacuum.tj@oerlikon.com

Oerlikon
Leybold Vacuum (Tianjin) International Trade Co. Ltd.
Beijing Branch:
1-908, Beijing Landmark Towers
8 North Dongsanhuan Road
Chaoyang District
Beijing 100004
China
Sales:
Phone: +86-10-6590-7622
Fax: +86-10-6590-7607
sales.vacuum.bj@oerlikon.com

India
Oerlikon
Leybold Vacuum India Pvt Ltd.
EL-22, J Block
MIDC Bhosari
Pune 411026
India
Sales and Service:
Phone: +91-20-3061 60000
Fax: +91-20-2712 1571
sales.vacuum.pu@oerlikon.com
service.vacuum.pu@oerlikon.com

Japan
Oerlikon
Leybold Vacuum Japan Co., Ltd.
Headquarter
23-3, Shin-Yokohama
3-chome
Tobu A.K. Bldg. 4th Floor
Kohoku-ku
Yokohama-shi 222-0033
Sales:
Phone: +81-45-471-3330
Fax: +81-45-471-3323
info.vacuum.yh@oerlikon.com
sales.vacuum.yh@oerlikon.com

Oerlikon
Leybold Vacuum Japan Co., Ltd.
Osaka Sales Office
5-13, Kawagishi-machi
Suita-chi
Osaka 564-0037
Phone: +81-6-6393-5211
Fax: +81-6-6393-5215
info.vacuum.os@oerlikon.com
sales.vacuum.os@oerlikon.com

Oerlikon
Leybold Vacuum Japan Co., Ltd.
Tsukuba Technical Service Center
Kogyo Danchi
21, Kasuminosato,
Ami-machi, Inashiki-gun
Ibaraki-ken, 300-0315
Service:
Phone: +81-298 89 2841
Fax: +81-298 89 2838
info.vacuum.iik@oerlikon.com
sales.vacuum.iik@oerlikon.com

Korea
Oerlikon
Leybold Vacuum Korea Ltd.
3F, Jellzone 2 Tower, 159-4
Jeongja-Dong, Bundang-Gu
Sungnam-Si, Gyeonggi-Do
Korea 463-384
Sales:
Phone: +82-31 785 1367
Fax: +82-31 785 1359

623-7, Upsung-Dong
Cheonan-Si
Chungcheongnam-Do
Korea 330-290
Service:
Phone: +82-41 589 3035
Fax: +82-41 588 0166

Singapore
Oerlikon
Leybold Vacuum Singapore Pte Ltd.
No.1, International Business Park
B1-20B, The Synergy
Singapore 609917

Sales and Service:
Phone: +65-6303 7000
Fax: +65-67730 039
sales.vacuum.sg@oerlikon.com
service.vacuum.sg@oerlikon.com

Taiwan
Oerlikon
Leybold Vacuum Taiwan Ltd.
No 416-1, Sec. 3
Chung-Hsin Rd., Chu-Tung
Hsin-Chu, Taiwan, R.O.C.
Sales and Service:
Phone: +886-3-500 1688
Fax: +886-3-583 3999
sales.vacuum.hc@oerlikon.com
service.vacuum.hc@oerlikon.com

oerlikon
leybold vacuum

www.oerlikon.com