

oerlikon
leybold vacuum

Vacuum Pump Systems RUTA

250 - 13 000 m³ x h⁻¹ (147 to 765 cfm)

173.02.02

Excerpt from the Oerlikon Leybold Vacuum Full Line Catalog

Product Section C08

Edition May 2007

Contents

General

Overview	C08.03
Types of Pumps Systems	C08.04

Products

Pump Systems (Global Versions)

Three-Stage RUTA Pump Systems with Two-Stage TRIVAC Backing Pumps	
Adaptor Version	C08.06
Frame Version	C08.08
Two-Stage RUTA Pump Systems with Single-Stage SOGEVAC Backing Pumps	
Adaptor Version	C08.10
Frame Version	C08.12
Two- and Three-Stage RUTA Pump Systems with Single- and Two-Stage Rotary Piston Vacuum Pumps as Backing Pumps	C08.14
Dry Compressing Vacuum Pump System RUTA with SCREWLINE SP630 Backing Pump	
Adaptor Version	C08.16
Frame Version	C08.18
RUVAC RAV Roots Vacuum Pumps with Pre-Admission Cooling	C08.20
Pump Systems RUTA RAV with RUVAC RAV Roots Vacuum Pumps	
Two- Stage	C08.22
Three-Stage	C08.24
TVD Pump Systems for Drying, Evaporation and Distillation Applications	C08.26
Pump Systems (Only available for purchase in North and South America)	
RBS - B/BCS Roots Pump Systems with Two-Stage TRIVAC Backing Pumps	C08.28
HTS Close-Coupled Pump Systems with Single-Stage SOGEVAC Backing Pumps	C08.32
SP Close-Coupled Pump Systems with SCREWLINE Dry Compressing Backing Pumps	C08.36

Accessories

Sound Proofing	C08.40
Isolation against Vibrations	C08.40
Dust Separators	C08.40
Frequency Inverter RUVATRONIC RT 5	C08.40
Electric Controller	C08.41
Pressure Control	C08.41
Dust Filter F-xxx-C	C08.42

Miscellaneous

Checklist for Inquiries (Fax Form)	C08.44
--	--------

General

Overview

A continually increasing number of applications in industry and research are relying on vacuum technology. Thus widely differing requirements result regarding the vacuum generating systems.

The comprehensive range of vacuum pumps from Oerlikon Leybold Vacuum offers, in combination with the matching accessories, all options of selecting the optimum pump system for your application in each case.

Based on the longstanding experience in the design and manufacture of vacuum pump systems, Oerlikon Leybold Vacuum offers standardized pump systems which will match most applications – the RUTA pump systems.

RUTA pump systems excel by being compact, reliable and service-friendly.

The pump systems are equipped as standard with 400 V, 50 Hz three-phase motors.

Motors for special supply voltages, special mains frequencies or explosion protected pumps are available.

Standards

Oerlikon Leybold Vacuum pump systems are rated according to CE, ISO, DIN and VDE regulations. Compliance with other standards is possible upon request.

The technical data of the vacuum pump systems given in this product section are based on the PNEUROPE Acceptance Specifications for Vacuum Pumps, Part 1, and comply with DIN 28 426. The characteristic curves in our pumping speed diagrams are plotted in accordance with DIN 28 426. The curves represent the mean of several measurements. Our warranty refers to the values indicated in the technical data table.

Designation of Roots Vacuum Pump Systems

Oerlikon Leybold Vacuum pump combinations of Roots vacuum pumps with backing pumps are called "RUTA".

In order to identify the standard pump systems the name "RUTA" is followed by the brief designations of the pumps which make up a particular pump system.

Brief designation of the largest Roots vacuum pump (Pumping speed of the pump system)

Brief designation of the smaller Roots vacuum pump

Cooler or condenser (if present)

Brief designation of the backing pump

Type of pump system (adaptor (A) or frame (G))

The pump system designation is arranged as follows:

RUTA WAU 2001 / WAU 501 / K / D 65 B / A

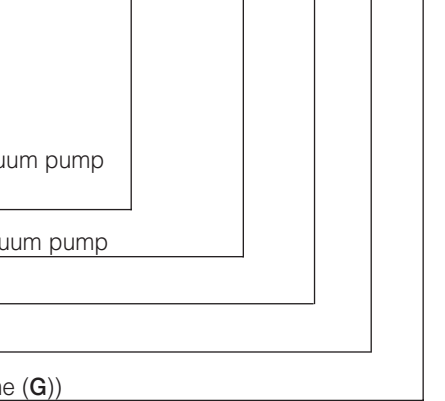

Types of Pump Systems

Typical areas of application for RUTA pump systems are industry, research and chemistry. Here the focus is on processes for metal production and processing, drying and degassing, thermal treatment, coating in the area of semiconductor manufacture as well as surface refinement. RUTA pump systems are also used as backing pump sets for high vacuum systems in combination with diffusion pumps, turbomolecular pumps and cryo pumps.

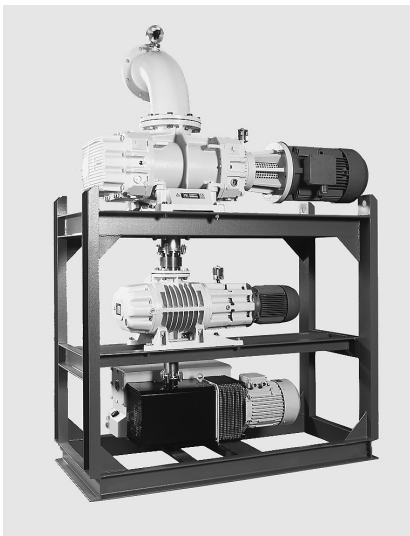

RUTA RA 3001/WAU1001/SV300

The RUTA pump systems described here have been designed for rough and medium vacuum operation, i.e. for the pressure range from atmospheric pressure down to 10^{-4} mbar (7.5×10^{-5} Torr). RUTA pump systems consist of a combination of individual pumps whereby Roots vacuum pumps are employed on the intake side. Further compression to atmospheric pressure may be performed either by oil-sealed or drycompressing vacuum pumps, liquid ring pumps or Roots vacuum pumps with pre-inlet cooling. All combinations may be equipped at suitable places with condensers.

The selection criteria for a RUTA pump system are as follows:

- Pumping speed
- Operating pressure
- Process conditions
- Characteristics of the media
- Standards and regulations which depend on the area of application and the produced products.

Standard RUTA Pump Systems

Our Roots vacuum pumps WA, WS and RA or WAU and WSU with integrated bypass line or RA with external bypass line (RAU) are combined with oil-sealed backing pumps for conventional generation of the vacuum. Single stage arrangements are capable of delivering pumping speeds of 250 to 16 000 m³/h (147.3 to 9424 cfm). Higher pumping speeds can be attained by paralleling several pumps. The attainable operating pressures depend on the number of pumping stages.

For higher pumping speeds or lower ultimate pressures, three or multi-stage pump systems equipped with single or two-stage backing pumps are available (see figure).

RUTA Pump Systems with Condensers

If vacuum systems must pump larger quantities of vapor or vapor gas mixtures, it is economical to insert condensers which are cooled with water or a different coolant at a suitable place within the pump system. Cooled condensers are themselves effective partial pumps which condense most of the vapors from the pumped media. The downstream mechanical pumps will then only need to pump those gases which have not already condensed.

The quantity of vapor present in each case determines the size of the condenser and the temperature at which

it is operated. The size of the downstream pump is determined by the quantity of non-condensable gases, the required pressure and the required pump-down time for the system.

All pump systems of the WA/WAU, WS/WSU and RA series may be equipped with one or several condensers. These are often used in the chemical industry. Here RUTA vacuum pump systems with condensers are not only used to generate a vacuum, but they are also often employed in the recovery of solvents. When installing one or several Roots pumps upstream of a condenser, low operating pressures and high condensation pressures can be attained. Thus the condenser may in many cases be operated with cooling water instead of brine. The vapor components pumped together with inert gases may be separated once more in an emission condenser on the exhaust side so that the quality of the exhaust gas can be maintained within close tolerance regarding its cleanness.

Dry-Compressing RUTA Vacuum Pump Systems

Increasing environmental awareness, pumping of condensable vapors or high requirements regarding cleanliness when pumping highquality media which must not be contaminated by other media for recycling, often requires the use of universal pumps where the pump chamber is free of operating agents (dry pumps).

Here Oerlikon Leybold Vacuum offers two solutions:

1. Pump systems consisting of the SCREWLINE screw vacuum pump developed specifically for the process industry in combination with one or several Roots vacuum pumps.
2. Single or multistage RUTA RAV vacuum pump systems, consisting of Roots vacuum pumps with pre-admission cooling.

The operating pressure ranges of the pump systems depend on the number of Roots vacuum pumps, but will extend in any case without interruptions to atmospheric pressure.

Already in connection with one Roots pump, pump systems with a SCREWLINE pump are capable of attaining base pressures of $< 1 \times 10^{-3}$ mbar (7.5×10^{-4} Torr).

Single-stage RAV combinations attain an ultimate pressure of 150 mbar (112.5 Torr) and twostage combinations 50 mbar (37.5 Torr).

Multi-stage combinations with Roots vacuum pumps of all systems are capable of attaining pressures below 10^{-4} mbar (7.5×10^{-5} Torr).

RUTA Custom Pump Systems

Most users will be able to select the right pump system for their application from our range of standard pump systems. In special cases a custom design may be required for special processes and high pumping speeds.

We are prepared to design and manufacture custom pump systems according to customers specifications. If required we will use - besides oil-sealed and dry-compressing backing pumps - liquid ring and ejector pumps.

RUTA Pump Systems for the Metal Producing and Processing Industry

In common vacuum furnace processes such as hardening, annealing, brazing, melting and casting, preferably oil-sealed or dry compressing standard vacuum pump systems are usually used. The oil-sealed systems consist of a combination of Roots vacuum pumps with a single or two-stage rotary vane or rotary piston pump.

In the dry compressing systems our screw vacuum pump SCREWLINE is used as the backing pump.

The vacuum pumps are mounted in a rugged frame. The design of the pump systems is service-friendly, modular and can be easily upgraded with additional equipment.

On smaller furnaces RUVAC WAU Roots vacuum pumps are the most suitable because these may be cut-in at a higher operating pressure, while on larger furnaces and particularly where short pump-down cycles are required, the use of RUVAC RA Roots vacuum pumps with suitably sized backing pumps is advisable. For special processes, e.g. fusion or degassing of molten masses, due to the high dust contents, the additional use of a dust separator is required as well as equipping the backing pumps with oil filtering units.

RUTA Pump Systems for the Chemical Industry

In chemical processes it is often necessary to remove corrosive, condensable and reactive gases and vapors. Oerlikon Leybold Vacuum designs and manufactures custom-built pump systems for specific process applications. Depending on the type of application, either a rotary vane pump, or a dry compressing screw vacuum pump (SCREWLINE, for example), a liquid ring pump or a combination of gas jet pump and liquid ring pump may be used as the backing pump.

To ensure dependable monitoring of the system, the following monitoring devices, among others, may be installed:

- Temperature sensors to monitor the gas temperatures between the pump stages and the pump body temperature,
- Water flow monitors for the cooling water supply to pumps and condensers,
- Differential pressure indicator with control setpoint to monitor the exhaust filters of the rotary vane vacuum pump.

Pump Systems for Drying, Evaporation and Distillation Applications (TVD)

More and more vacuum applications are finding their way into the areas of environmental protection, recycling and waste disposal. "Waste disposal of used oil and aromatic compounds" and "Cleaning processes in metal-processing factories" demonstrate that the combination of vacuum know-how, innovative engineering and applications know-how is indispensable for the successful application of vacuum technology in most widely differing applications.

The product is no longer in the foreground, solutions to problems are demanded instead.



TVD pump system, mobile with control cabinet

Oerlikon Leybold Vacuum has developed some continuously operating vacuum pump systems for these applications. These systems basically consist of a rotary vane pump with a condenser unit. Upon request the condenser arrangement may also be equipped with a cold water set. This version will then be independent of any cooling water connections and – being a mobile system – it is well-suited for operation at varying locations.

Products

Three-Stage RUTA Pump Systems with Two-Stage TRIVAC Backing Pumps, Adaptor Version



RUTA WAU 501/D65B/A

Standard Equipment

- Exhaust filter
- Oil collecting pan
- Manually operated gas ballast
- Crane eyes on the frame
- Floor mounting
- The oil is supplied with the pump
- CE approval

Options

- Frequency inverter
- RUVATRONIC RT for controlling the speed of the Roots pump
- Oil filter
- 24 V DC gas ballast valve
- Sound proofing box
- Vibration absorbers

- Castors
- Different types of floor mounts
- Oil drain valve on each pump
- Exhaust filter with oil return line
- Special motors
- Electric control systems

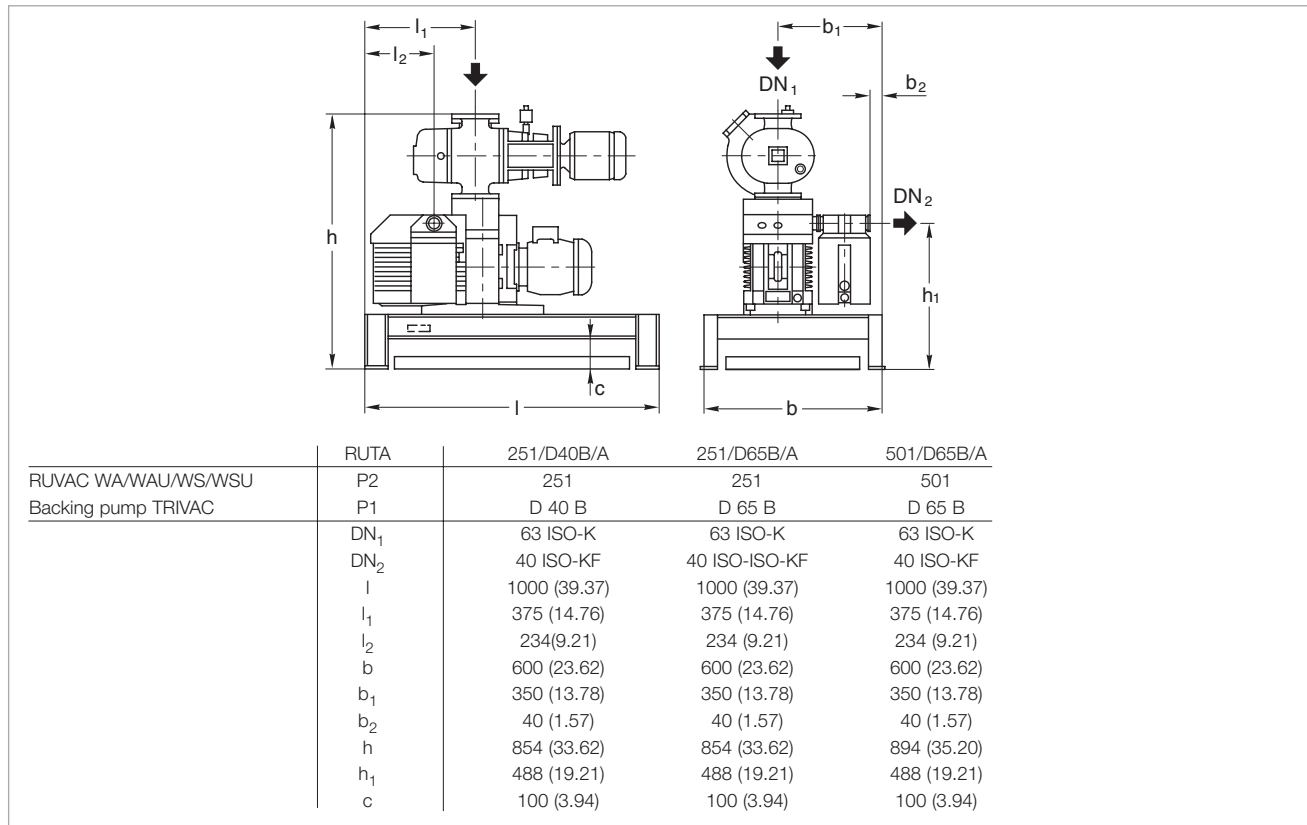

Dimensional drawing for the pump systems with TRIVAC D40/65 B backing pumps on pallet; dimensions in brackets () are in inch

Technical Data, 50 Hz

		RUTA WAU		
		251/D40B/A	251/D65B/A	501/D65B/A
RUVAC (WA/WAU/WS/WSU possible)	P2	251	251	501
Backing pump TRIVAC	P1	D 40 B	D 65 B	D 65 B
Pumping speed, 50 Hz at 10^{-1} mbar (7.5×10^{-2} Torr)	$m^3 \times h^{-1}$ (cfm)	200.0 (117.8)	210.0 (123.7)	380.0 (223.8)
Ultimate partial pressure	mbar (Torr)	$< 2 \times 10^{-5}$ ($< 1.5 \times 10^{-5}$)	$< 2 \times 10^{-5}$ ($< 1.5 \times 10^{-5}$)	$< 2 \times 10^{-5}$ ($< 1.5 \times 10^{-5}$)
Ultimate total pressure with gas ballast	mbar (Torr)	$< 8 \times 10^{-4}$ ($< 6 \times 10^{-4}$)	$< 8 \times 10^{-4}$ ($< 6 \times 10^{-4}$)	$< 8 \times 10^{-4}$ ($< 6 \times 10^{-4}$)
Installed motor power	kW (hp)	2.6 (3.5)	3.3 (4.5)	4.4 (6.0)
Power consumption at 10^{-1} mbar (7.5×10^{-2} Torr)	kW (hp)	2.0 (2.7)	2.5 (3.4)	2.7 (3.7)
Noise level to DIN 45 635 max.	dB(A)	64	65	67
without gas ballast at 1 mbar (0.75 Torr)	dB(A)	62	63	63
Oil filling, total, approx.	l (qt)	3.3 (3.49)	4.0 (4.23)	4.3 (4.55)
Weight, total, approx.	kg (lbs)	245.0 (540.2)	260.0 (573.3)	305.0 (627.5)
Connecting flange				
Inlet port	DN ₁	63 ISO-K	63 ISO-K	63 ISO-K
Outlet port	DN ₂	40 ISO-KF	40 ISO-KF	40 ISO-KF

Ordering Information

		RUTA WAU		
		251/D40B/A	251/D65B/A	501/D65B/A
RUVAC (WA/WAU/WS/WSU possible)	P2	WAU 251	WAU 251	WAU 501
Backing pump TRIVAC	P1	D 40 B	D 65 B	D 65 B
Pump system, complete (adaptor version), pallet mounted, with Roots vacuum pump RUVAC WAU		Part No. 023 06	Part No. 023 07	Part No. 023 08
Frequency inverter RUVATRONIC (see description in Section "Accessories")		RT 5/251 Part No. 500 001 381	RT 5/251 Part No. 500 001 381	RT 5/501 Part No. 500 001 382

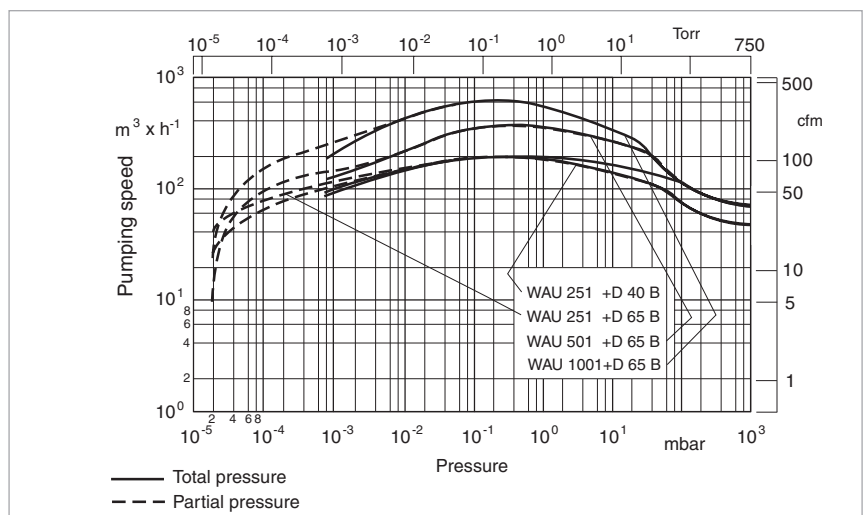
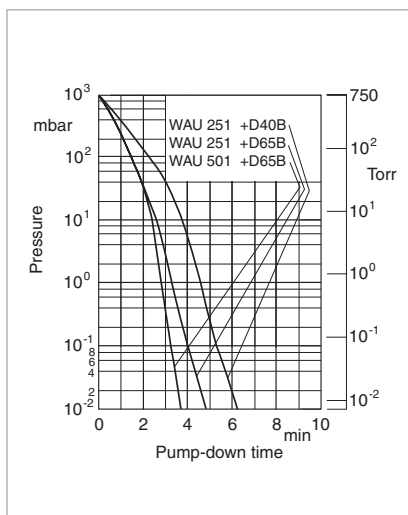

Pump-down time diagram for a 10 m³ tank at 50 Hz Pumping speed diagram at 50 Hz

Three-Stage RUTA Pump Systems with Two-Stage TRIVAC Backing Pumps, Frame Version



RUTA WAU 501/D65B/G

Standard Equipment

- Exhaust filter
- Oil collecting pan
- Manually operated gas ballast
- Crane eyes on the frame
- Floor mounting
- The oil is supplied with the pump
- CE approval

Options

- Frequency inverter
RUVATRONIC RT for controlling
the speed of the Roots pump
- Oil filter
- 24 V DC gas ballast valve
- Sound proofing box
- Vibration absorbers

- Castors
- Different types of floor mounts
- Oil drain valve on each pump
- Exhaust filter with oil return line
- Special motors
- Electric control systems

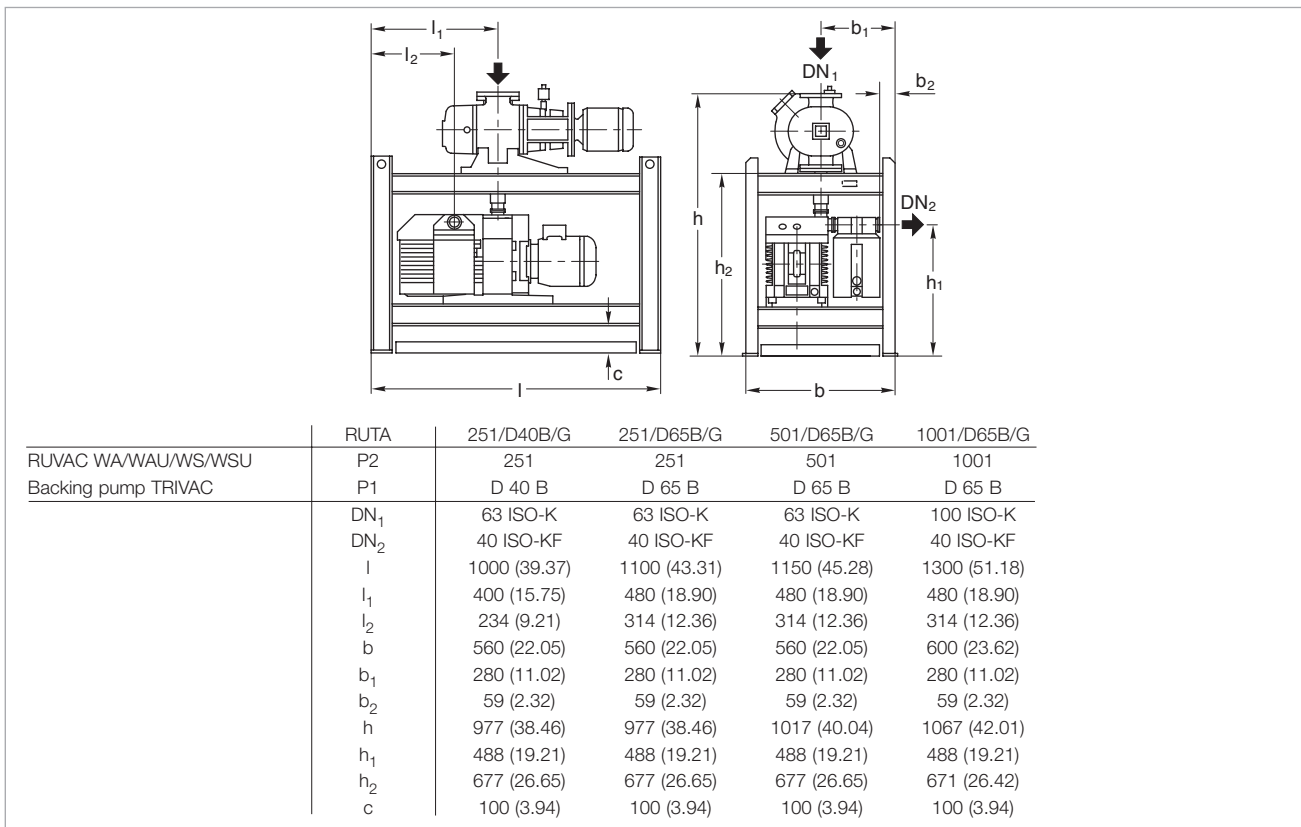

Dimensional drawing for the pump systems with TRIVAC D40/65 B backing pumps in a frame; dimensions in brackets () are in inch

Technical Data, 50 Hz

		RUTA WAU			
		251/D40B/G	251/D65B/G	501/D65B/G	1001/D65B/G
RUVAC (WA/WAU/WS/WSU possible)	P2	251	251	501	1001
Backing pump TRIVAC	P1	D 40 B	D 65 B	D 65 B	D 65 B
Pumping speed, 50 Hz at 10^{-1} mbar (7.5×10^{-2} Torr)	$m^3 \times h^{-1}$ (cfm)	185.0 (109.0)	205.0 (120.7)	340.0 (200.3)	620.0 (365.2)
Ultimate partial pressure	mbar (Torr)	$< 2 \times 10^{-5}$ ($< 1.5 \times 10^{-5}$)	$< 2 \times 10^{-5}$ ($< 1.5 \times 10^{-5}$)	$< 2 \times 10^{-5}$ ($< 1.5 \times 10^{-5}$)	$< 2 \times 10^{-5}$ ($< 1.5 \times 10^{-5}$)
Ultimate total pressure with gas ballast	mbar (Torr)	$< 8 \times 10^{-4}$ ($< 6 \times 10^{-4}$)	$< 8 \times 10^{-4}$ ($< 6 \times 10^{-4}$)	$< 8 \times 10^{-4}$ ($< 6 \times 10^{-4}$)	$< 8 \times 10^{-4}$ ($< 6 \times 10^{-4}$)
Installed motor power	kW (hp)	2.6 (3.5)	3.3 (4.5)	4.4 (6.0)	6.2 (8.4)
Power consumption at 10^{-1} mbar (7.5×10^{-2} Torr)	kW (hp)	2.0 (2.7)	2.5 (3.4)	2.7 (3.7)	3.0 (4.1)
Noise level to DIN 45 635 max.	dB(A)	64	65	67	77
without gas ballast at 1 mbar (0.75 Torr)	dB(A)	62	63	63	70
Oil filling, total, approx.	l (qt)	3.3 (4.5)	4.0 (4.23)	4.3 (4.55)	5.3 (5.60)
Weight, total, approx.	kg (lbs)	280.0 (617.4)	310.0 (683.6)	350.0 (771.8)	460.0 (1014.3)
Connecting flange					
Inlet port	DN ₁	63 ISO-K	63 ISO-K	63 ISO-K	100 ISO-K
Outlet port	DN ₂	40 ISO-KF	40 ISO-KF	40 ISO-KF	40 ISO-KF

Ordering Information

		RUTA WAU			
		251/D40B/G	251/D65B/G	501/D65B/G	1001/D65B/G
RUVAC (WA/WAU/WS/WSU possible)	P2	WAU 251	WAU 251	WAU 501	WAU 1001
Backing pump TRIVAC	P1	D 40 B	D 65 B	D 65 B	D 65 B
Pump system, complete (frame version), frame mounted, with Roots vacuum pump RUVAC WAU		Part No. 023 16	Part No. 023 17	Part No. 023 18	Part No. 023 19
Frequency inverter RUVATRONIC (see description in Section "Accessories")		RT 5/251 Part No. 500 001 381	RT 5/251 Part No. 500 001 381	RT 5/501 Part No. 500 001 382	RT 5/1001 Part No. 500 001 383

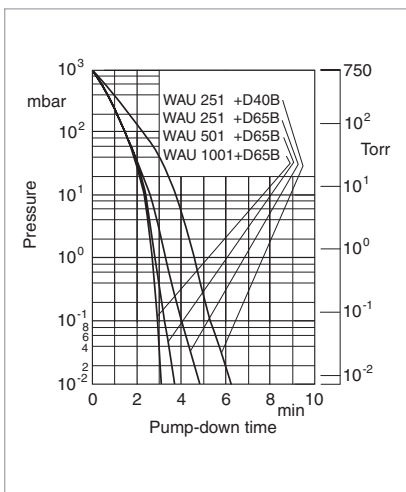

Pump-down time diagram for a 10 m³ tank at 50 Hz

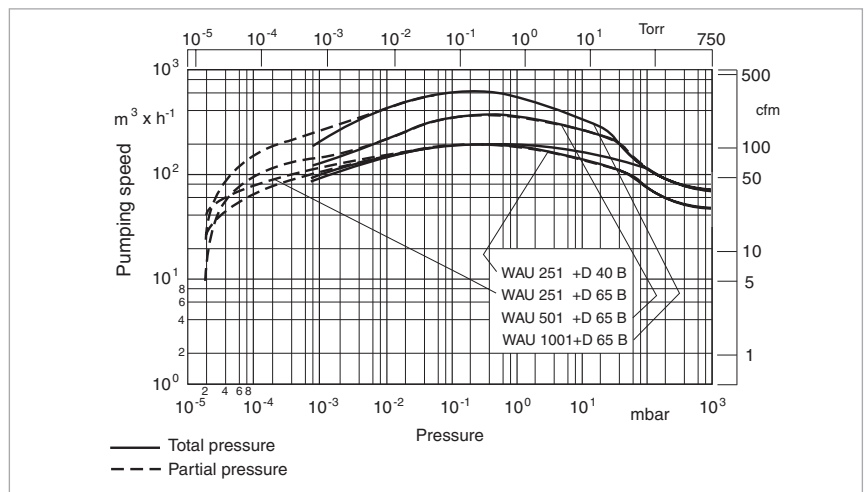

Pumping speed diagram at 50 Hz

Two-Stage RUTA Pump Systems with Single-Stage SOGEVAC Backing Pumps, Adaptor Version

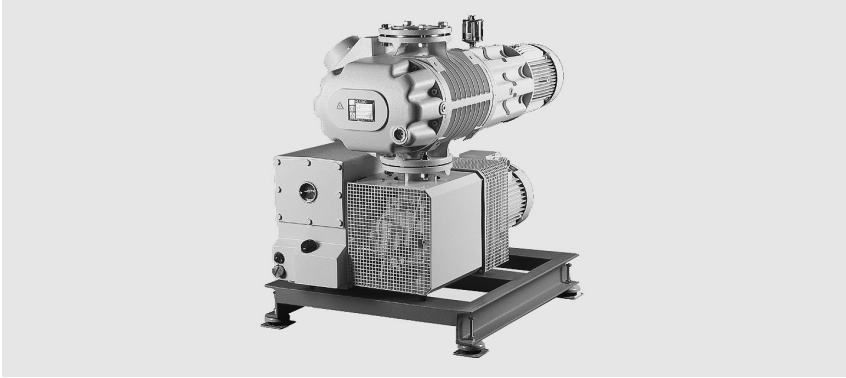

RUTA WAU 1001/SV200/A

Standard Equipment

- Exhaust filter with oil return line
- Oil filter
- Oil collecting pan
- Manually operated gas ballast
- Floor mounting
- The oil is supplied with the pump
- CE approval

Options

- Frequency inverter RUVATRONIC RT for controlling the speed of the Roots pump
- 24 V DC gas ballast valve
- Sound proofing box
- Vibration absorbers
- Castors

- Different types of floor mounts
- Oil drain valve on each pump
- Special motors
- Electric control systems

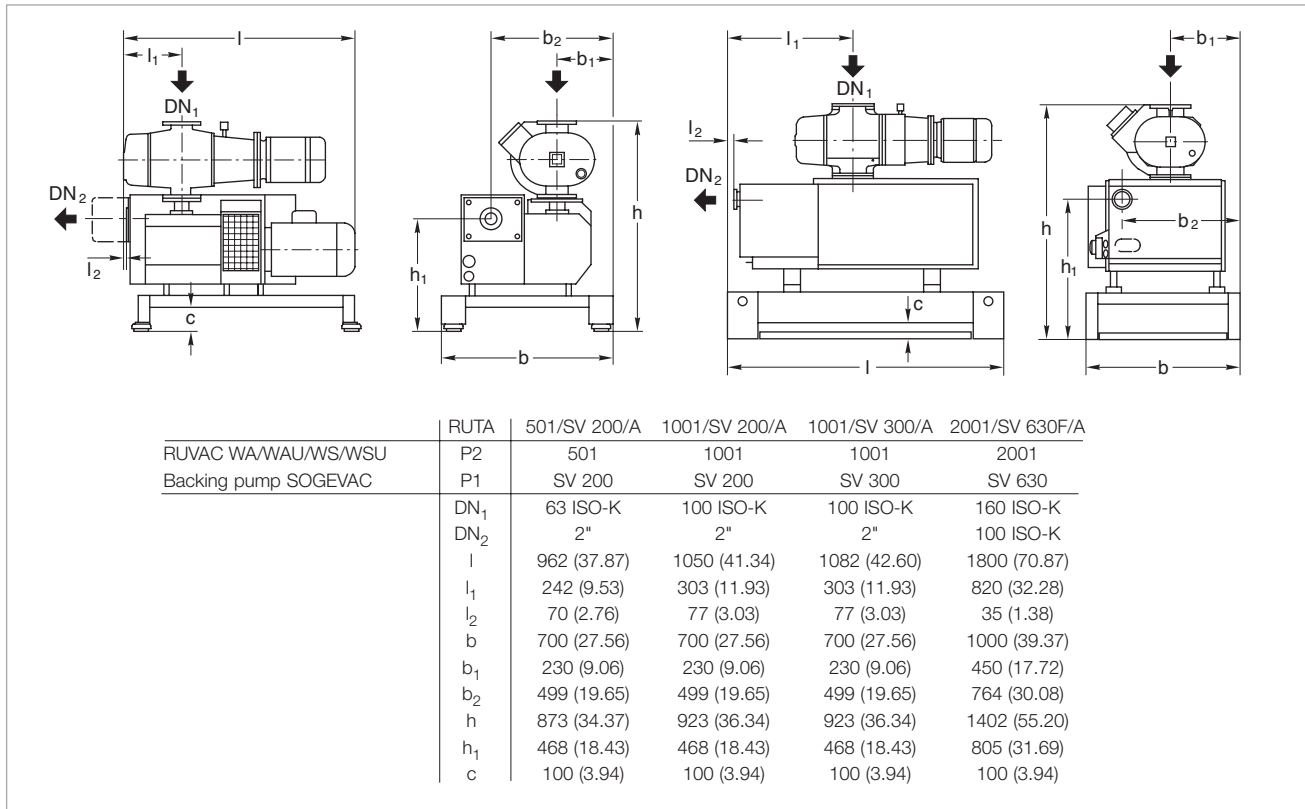

Dimensional drawing for the pump systems with SOGEVAC SV 200 and 300 backing pumps [left], SOGEVAC SV 630 F [right]; dimensions in brackets () are in inch

Technical Data, 50 Hz

		RUTA WAU			
		501/SV200/A	1001/SV200/A	1001/SV300/A	2001/SV630F/A
RUVAC (WA/WAU/WS/WSU possible)	P2	501	1001	1001	2001
Backing pump SOGEVAC	P1	SV 200	SV 200	SV 300	SV 630 F
Pumping speed, 50 Hz at 10 ⁻¹ mbar (7.5 x 10 ⁻² Torr)	m ³ x h ⁻¹ (cfm)	365.0 (215.0)	715.0 (421.0)	730.0 (430.0)	1690.0 (995.4)
Ultimate partial pressure	mbar (Torr)	< 8 x 10 ⁻³ (< 6 x 10 ⁻³)	< 8 x 10 ⁻³ (< 6 x 10 ⁻³)	< 8 x 10 ⁻³ (< 6 x 10 ⁻³)	< 8 x 10 ⁻³ (< 6 x 10 ⁻³)
Ultimate total pressure with gas ballast	mbar (Torr)	< 4 x 10 ⁻² (< 3 x 10 ⁻²)	< 4 x 10 ⁻² (< 3 x 10 ⁻²)	< 4 x 10 ⁻² (< 3 x 10 ⁻²)	< 4 x 10 ⁻² (< 3 x 10 ⁻²)
Installed motor power	kW (hp)	6.2 (8.4)	8.0 (10.9)	9.5 (12.9)	22.5 (30.6)
Power consumption at 10 ⁻¹ mbar (7.5 x 10 ⁻² Torr)	kW (hp)	3.0 (4.1)	3.5 (4.8)	4.0 (5.4)	16.5 (22.4)
Noise level to DIN 45 635 without gas ballast at 10 ⁻¹ mbar (7.5 x 10 ⁻² Torr)	dB(A)	70	75	76	80
Oil filling, total, approx.	l (qt)	6.0 (6.34)	7.0 (7.4)	11.0 (11.63)	39.0 (41.23)
Weight, total, approx.	kg (lbs)	335.0 (738.7)	430.0 (948.2)	480.0 (1058.4)	1140.0 (2513.7)
Connecting flange					
Inlet port	DN ₁	63 ISO-K	100 ISO-K	100 ISO-K	160 ISO-K
Outlet port	DN ₂	2"	2"	2"	100 ISO-K

Ordering Information

		RUTA WAU			
		501/SV200/A	1001/SV200/A	1001/SV300/A	2001/SV630F/A
RUVAC (WA/WAU/WS/WSU possible)	P2	WAU 501	WAU 1001	WAU 1001	WAU 2001
Backing pump SOGEVAC	P1	SV 200	SV 200	SV 300	SV 630 F
Pump system, complete (adaptor version), pallet mounted, with Roots vacuum pump RUVAC WAU		Part No. 022 06	Part No. 022 08	Part No. 022 09	Part No. 022 11
Frequency inverter RUVATRONIC (see description in Section "Accessories")		RT 5/501 Part No. 500 001 382	RT 5/1001 Part No. 500 001 383	RT 5/1001 Part No. 500 001 383	RT 5/2001 Part No. 500 001 384

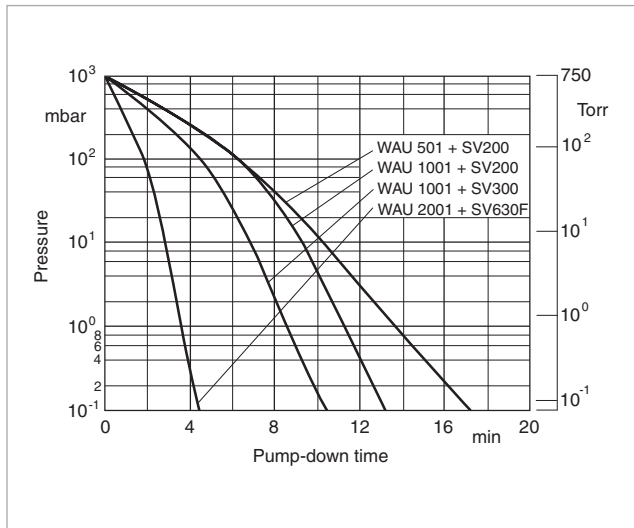

Pump-down time diagram for a 10 m³ tank at 50 Hz

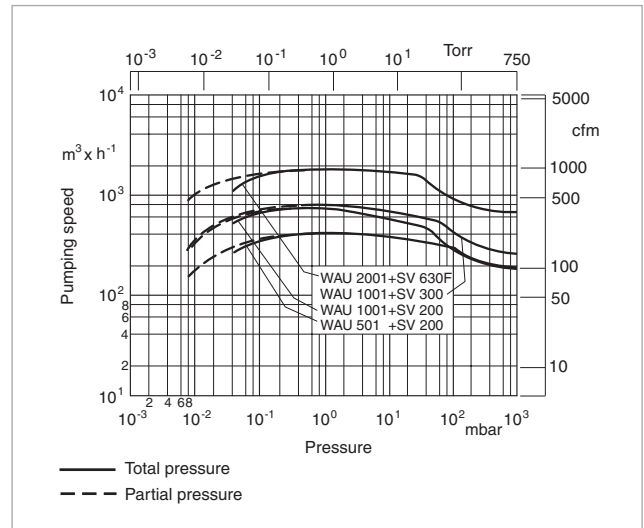

Pumping speed diagram at 50 Hz

Two-Stage RUTA Pump Systems with Single-Stage SOGEVAC Backing Pumps, Frame Version

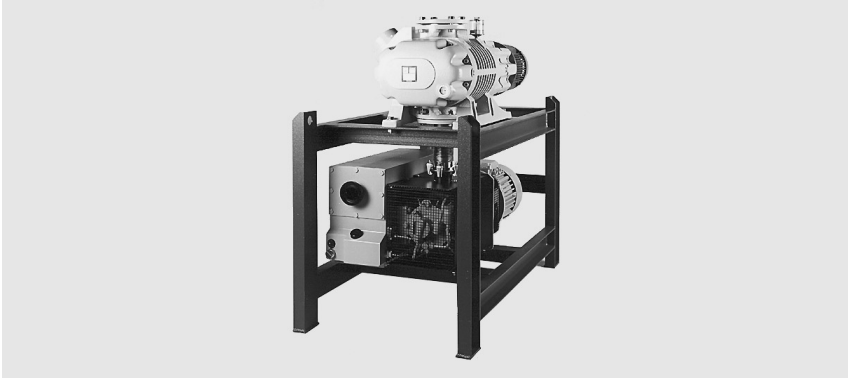

RUTA WAU 2001/SV300/G

Standard Equipment

- Exhaust filter with oil return line
- Oil filter
- Oil collecting pan
- Manually operated gas ballast
- Crane eyes on the frame
- Floor mounting
- The oil is supplied with the pump
- CE approval

Options

- Frequency inverter RUVATRONIC RT for controlling the speed of the Roots pump
- 24 V DC gas ballast valve
- Sound proofing box
- Vibration absorbers
- Castors
- Different types of floor mounts

- Oil drain valve on each pump
- Special motors
- Electric control systems

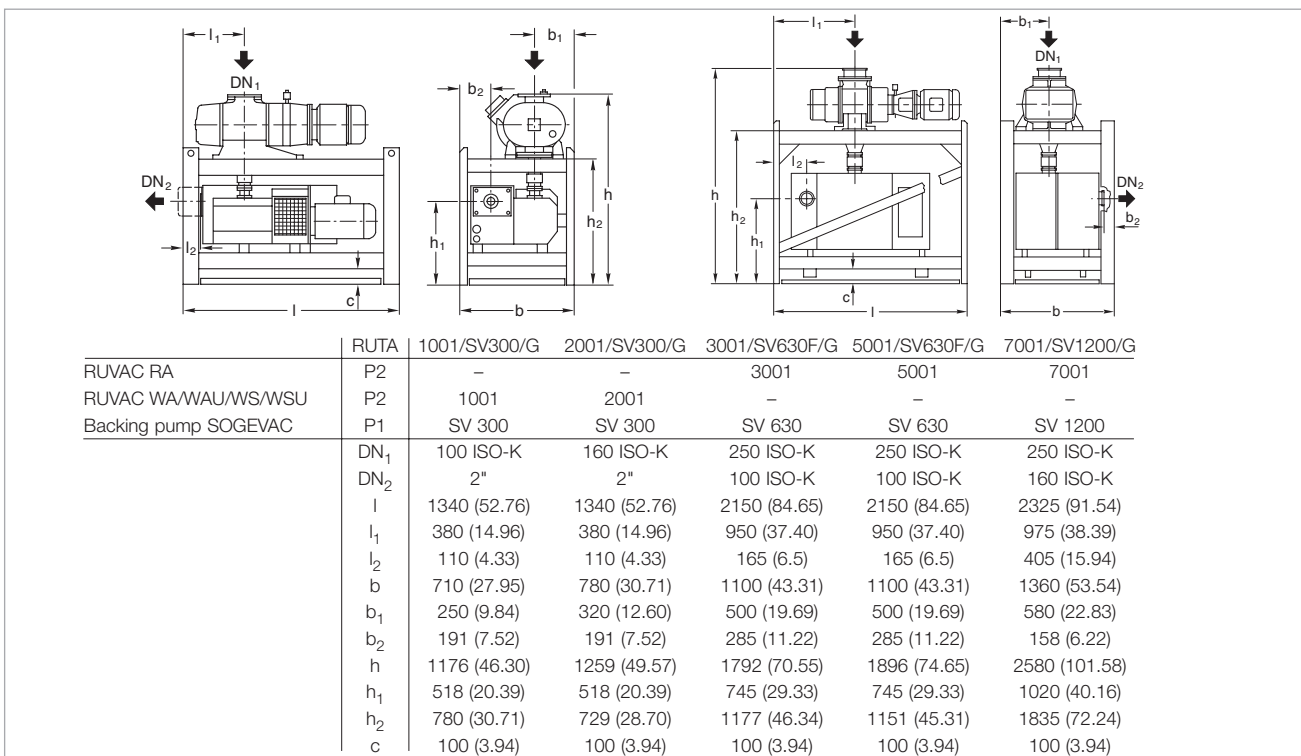

Dimensional drawing for the pump systems with SOGEVAC SV 300 and 630 F backing pumps [left], SOGEVAC SV 1200 [right]; dimensions in brackets () are in inch

Technical Data, 50 Hz

RUTA

1001/SV300/G 2001/SV300/G 3001/SV630F/G 5001/SV630F/G 7001/SV1200/G

RUVAC RA	P2	–	–	3001	5001	7001
RUVAC (WA/WAU/WS/WSU possible)	P2	1001	2001	–	–	–
Backing pump SOGEVAC	P1	SV 300	SV 300	SV 630 F	SV 630 F	SV 1200
Pumping speed, 50 Hz at 10^{-1} mbar (7.5×10^{-2} Torr)	$\text{m}^3 \times \text{h}^{-1}$ (cfm)	730 (430)	1445 (850)	3090 (1818)	4210 (2478)	5520 (3250)
Ultimate partial pressure	mbar (Torr)	$< 8 \times 10^{-3}$ ($< 6 \times 10^{-3}$)	$< 8 \times 10^{-3}$ ($< 6 \times 10^{-3}$)	$< 8 \times 10^{-3}$ ($< 6 \times 10^{-3}$)	$< 8 \times 10^{-3}$ ($< 6 \times 10^{-3}$)	$< 8 \times 10^{-3}$ ($< 68 \times 10^{-3}$)
Ultimate total pressure with gas ballast	mbar (Torr)	$< 4 \times 10^{-2}$ ($< 3 \times 10^{-2}$)	$< 4 \times 10^{-2}$ ($< 3 \times 10^{-2}$)	$< 4 \times 10^{-2}$ ($< 3 \times 10^{-2}$)	$< 4 \times 10^{-2}$ ($< 3 \times 10^{-2}$)	$< 4 \times 10^{-2}$ ($< 3 \times 10^{-2}$)
Installed motor power	kW (hp)	9.5 (12.9)	13.0 (17.7)	26.0 (35.4)	30.0 (40.8)	33.5 (45.6)
Power consumption at 10^{-1} mbar (7.5×10^{-2} Torr)	kW (hp)	4.0 (5.4)	4.5 (6.1)	17.0 (23.1)	17.5 (23.8)	18.0 (24.5)
Noise level to DIN 45 635 without gas ballast at 10^{-1} mbar (7.5×10^{-2} Torr)	dB(A)	75	79	82	80	82
Oil filling, total, approx.	l (qt)	11.0 (11.63)	13	42	47	62
Weight, total, approx.	kg (lbs)	560.0 (1234.8)	740.0 (1631.7)	1750.0 (3858.8)	1900.0 (4189.5)	3000.0 (6615)
Connecting flange Inlet port	DN ₁	100 ISO-K	160 ISO-K	250 ISO-K	250 ISO-K	250 ISO-K
Outlet port	DN ₂	2"	2"	100 ISO-K	100 ISO-K	160 ISO-K

Ordering Information

RUTA

1001/SV300/G 2001/SV300/G 3001/SV630F/G 5001/SV630F/G 7001/SV1200/G

RUVAC	P2	–	–	RA 3001	RA 5001	RA 7001
RUVAC (WA/WAU/WS/WSU possible)	P2	WAU 1001	WAU 2001	–	–	–
Backing pump SOGEVAC	P1	SV 300	SV 300	SV 630 F	SV 630 F	SV 1200
Pump system, complete (frame version), frame mounted, with Roots vacuum pump RUVAC RA RUVAC WAU		– Part No. 022 31	– Part No. 022 33	Part No. 022 35 –	Part No. 022 37 –	Part No. 022 39 –
Frequency inverter RUVATRONIC (see description in Section “Accessories”)		RT 5/1001 Part No. 500 001 383	RT 5/2001 Part No. 500 001 384	RT 5/3001 Part No. 500 001 385 1)	RT 5/5001 Part No. 500 001 386 1)	RT 5/7001 Part No. 500 001 387 1)

1) With this combination, continuous operation of the Roots pump is not possible at atmospheric pressure

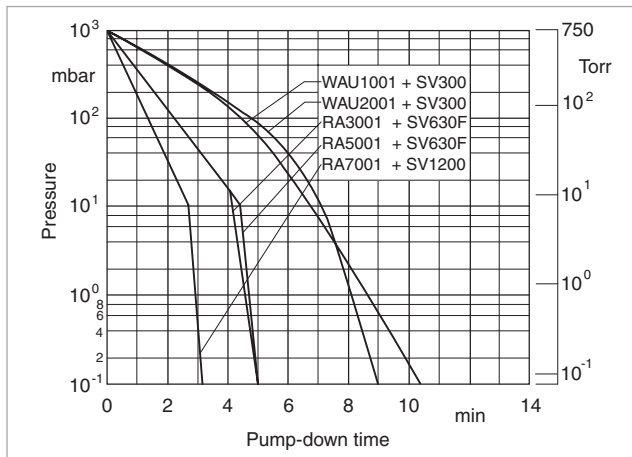

Pump-down time diagram for a 10 m³ tank at 50 Hz

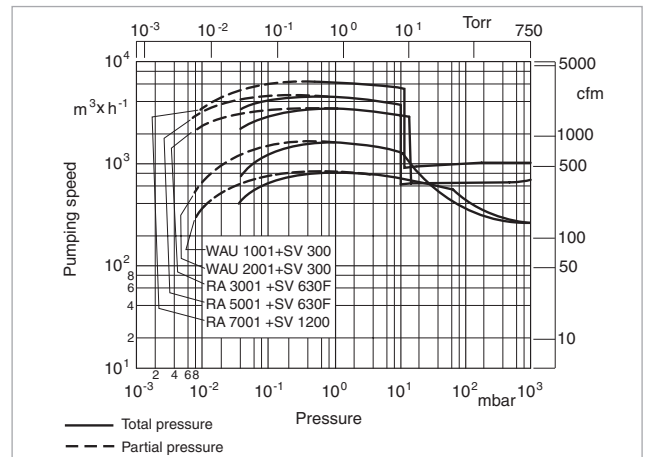

Pumping speed diagram at 50 Hz

Two and Three-Stage RUTA Pump Systems with Single- and Two-Stage Rotary Piston Vacuum Pumps as Backing Pump

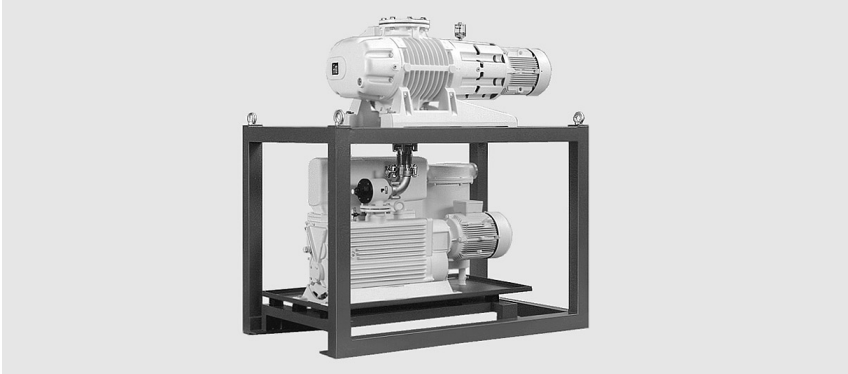

RUTA WAU 2001/E250/G

Standard Equipment

- Exhaust filter attached
- Oil collecting pan
- SECUVAC valve 24 V DC
- Backing pump removable by a fork lifter
- Crane eyes on the frame
- Floor mounting
- The oil is supplied with the pump
- CE approval

Options

- Frequency inverter RUVATRONIC RT for controlling the speed of the Roots pump
- Oil filter
- 24 V DC gas ballast valve
- Sound proofing box
- Vibration absorbers
- Different types of floor mounts

- Oil drain valve on each pump
- Exhaust filter box with oil return
- Special motors
- Electric control systems

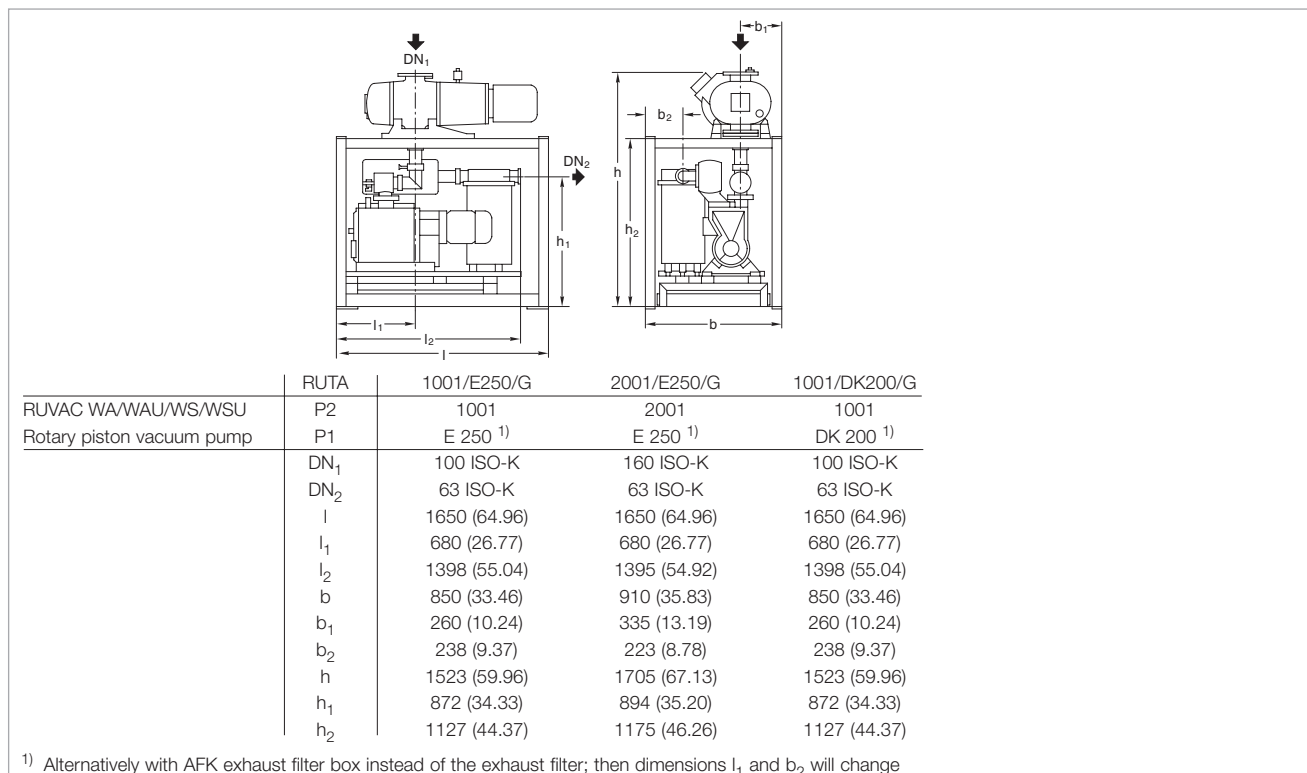

Dimensional drawing for the pump systems with E and DK backing pumps; dimensions in brackets () are in inch

Technical Data, 50 Hz

		RUTA WAU		RUTA WSU	
		1001/E250/G	2001/E250/G	1001/DK200/G	
RUVAC (WA/WAU/WS/WSU possible)	P2	1001	2001	1001	
Rotary piston vacuum pump	P1	E 250	E 250	DK 200	
Pumping speed, 50 Hz at 1 mbar (0.75 Torr) $\text{m}^3 \times \text{h}^{-1}$ (cfm) at 10^{-1} mbar (7.5×10^{-2} Torr)	$\text{m}^3 \times \text{h}^{-1}$ (cfm)	800.0 (471.2)	1350.0 (795.2)	–	
	$\text{m}^3 \times \text{h}^{-1}$ (cfm)	–	–	815.0 (480.0)	
Ultimate partial pressure	mbar (Torr)	2×10^{-3} (1.5×10^{-3})	2×10^{-3} (1.5×10^{-3})	3×10^{-5} (2.3×10^{-5})	
Ultimate total pressure with gas ballast	mbar (Torr)	2×10^{-2} (1.5×10^{-2})	2×10^{-2} (1.5×10^{-2})	3×10^{-4} (2.3×10^{-4})	
Installed motor power	kW (hp)	9.5 (12.9)	13.0 (17.7)	9.5 (12.9)	
Installed motor power at 1 mbar (0.75 Torr)	kW (hp)	4.0 (5.4)	4.7 (6.4)	–	
	at 10^{-1} mbar (7.5×10^{-2} Torr)	kW (hp)	–	4.4 (6.0)	
Noise level to DIN 45 635 max.	dB(A)	80	83	80	
	without gas ballast at 1 mbar (0.75 Torr)	dB(A)	75	80	–
	without gas ballast at 10^{-1} mbar (7.5×10^{-2} Torr)	dB(A)	–	–	75
Oil filling, total, approx.	l (qt)	11.0 (11.63)	12.0 (12.68)	6.0 (6.34)	
Weight, total, approx.	kg (lbs)	895.0 (1973.5)	1080.0 (2381.4)	930.0 (2050.7)	
Connecting flange					
	Inlet port	DN ₁	100 ISO-K	160 ISO-K	100 ISO-K
	Outlet port	DN ₂	63 ISO-K	63 ISO-K	63 ISO-K

Ordering Information

		RUTA WAU		RUTA WSU
		1001/E250/G	2001/E250/G	1001/DK200/G
RUVAC (WA/WAU/WS/WSU possible)	P2	WAU 1001	WAU 2001	WSU 1001
Rotary piston vacuum pump	P1	E 250	E 250	DK 200
Pump system, complete (frame version), frame mounted, with Roots vacuum pump	RUVAC WAU	Part No. 023 36	Part No. 023 45	–
	RUVAC WSU	–	–	Part No. 025 36
Frequency inverter RUVATRONIC (see description in Section “Accessories”)		RT 5/1001	RT 5/2001	RT 5/1001
		Part No. 500 001 383	Part No. 500 001 384	Part No. 500 001 383

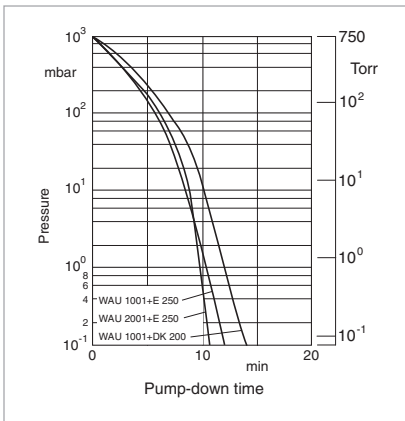

Pump-down time diagram for a 10 m^3 tank at 50 Hz

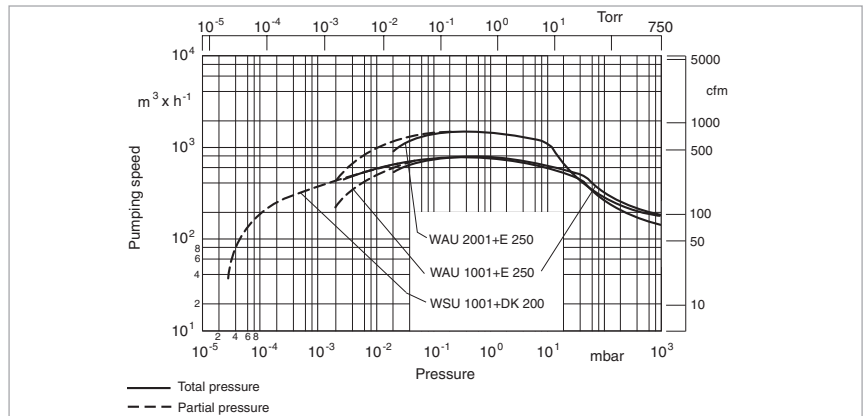

Pumping speed diagram at 50 Hz

Dry-Compressing Vacuum Pump System RUTA with SCREWLINE SP630 Backing Pump, Adaptor Version

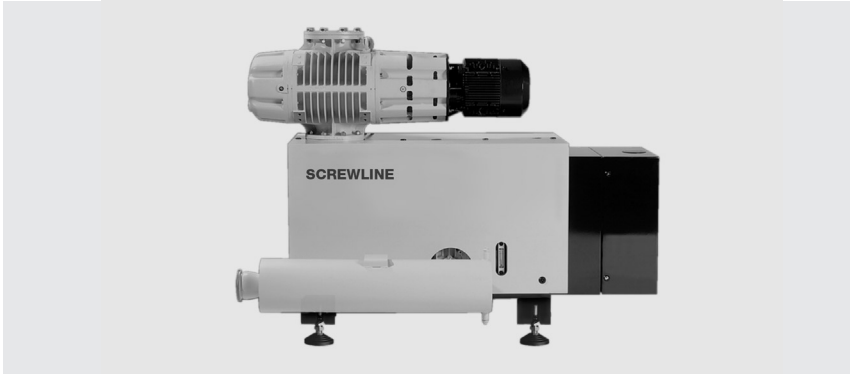

RUTA WSU 2001/SP630/A

Standard Equipment

- Silencer
- SP Guard
- Manually operated gas ballast
- Gear oil collecting pan integrated within the SCREWLINE
- Gear oil supplied with the pump
- CE approval

Options

- Frequency inverter RUVATRONIC RT for controlling the speed of the Roots pump
- Condensate drain valve at the silencer
- Sound proofing box
- Vibration absorbers

- SCREWLINE with water cooling
- Castors
- Different types of floor mounts
- Oil drain valve on each pump
- Electric control systems

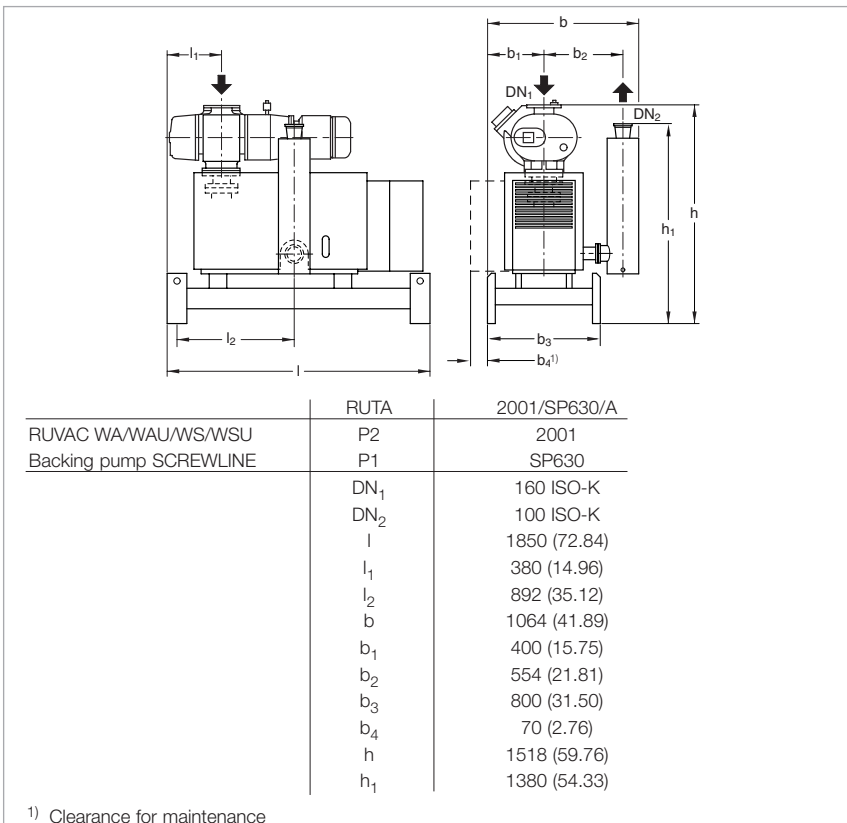

Dimensional drawing of the pump systems with dry compressing SCREWLINE SP630 backing pump, adaptor version; dimensions in brackets () are in inch

Technical Data, 50 Hz

RUTA WAU 2001/SP630/A

RUVAC (WA/WAU/WS/WSU possible)	P2	2001
Backing pump SCREWLINE	P1	SP630
Pumping speed, 50 Hz at 10^{-1} mbar (7.5×10^{-2} Torr)	$\text{m}^3 \times \text{h}^{-1}$ (cfm)	1780 (1050)
Ultimate total pressure without gas ballast	mbar (Torr)	$< 1 \times 10^{-3}$ ($< 7.5 \times 10^{-4}$)
Installed motor power	kW (hp)	22.5 (30.0)
Electrical power consumption at 10^{-1} mbar (7.5×10^{-2} Torr)	kW (hp)	11.7 (15.7)
Noise level to DIN 45 635 with silencer at 10^{-1} mbar (7.5×10^{-2} Torr)	dB(A)	79
Weight, total, approx.	kg (lbs)	1100 (2430)
Connecting flange		
Inlet port	DN ₁	160 ISO-K
Outlet port	DN ₂	100 ISO-K

Ordering Information

RUTA WAU 2001/SP630/A

RUVAC (WA/WAU/WS/WSU possible)	P2	WAU 2001
Backing pump SCREWLINE	P1	SP630
Pump system, complete (adaptor version), pallet mounted, with Roots vacuum pump RUVAC WAU		Part No. 500 740
Frequency inverter RUVATRONIC (see description in Section "Accessories")		RT 5/2001 Part No. 500 001 384

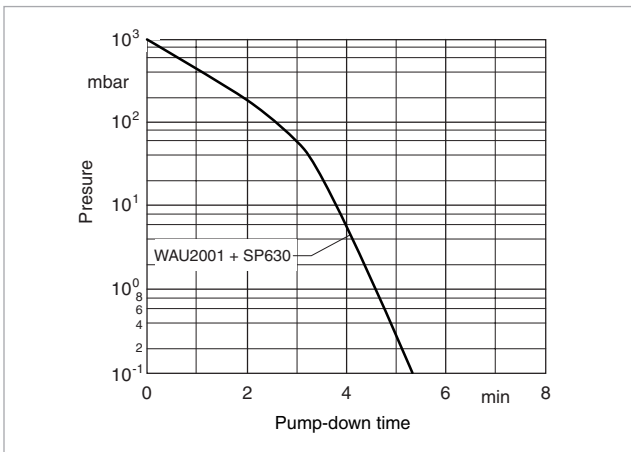

Pump-down time diagram for a 10 m³ tank at 50 Hz

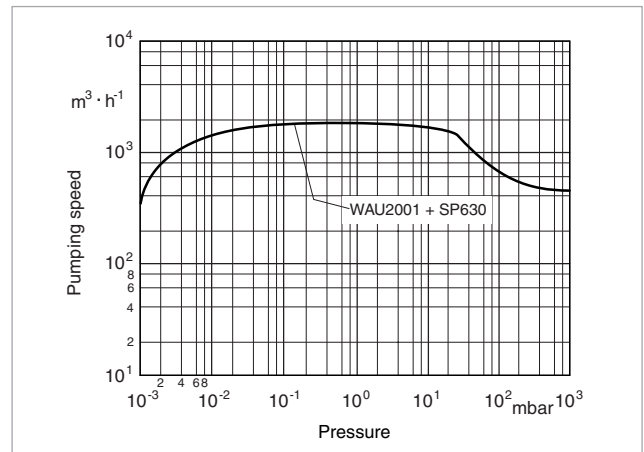

Pumping speed diagram at 50 Hz

Dry-Compressing Vacuum Pump System RUTA with SCREWLINE SP630 Backing Pump, Frame Version

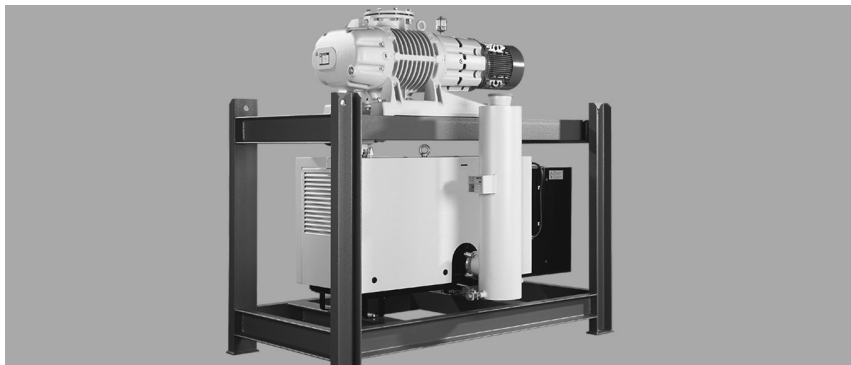

RUTA WAU 2001/SP630/G

Standard Equipment

- Silencer
- SP Guard
- Manually operated gas ballast
- SECUVAC valve 24 V DC
- Gear oil collecting pan integrated within the SCREWLINE
- Crane eyes on the frame
- Floor mounting

- Gear oil supplied with the pump
- CE approval

Options

- Frequency inverter RUVATRONIC RT for controlling the speed of the Roots pump
- Condensate drain valve at the silencer
- Sound proofing box

- Vibration absorbers
- SCREWLINE with water cooling
- Castors
- Different types of floor mounts
- Oil drain valve on each pump
- Electric control systems

	RUTA	2001/SP630/G	3001/SP630/G	5001/SP630/G	7001/SP630/G	9001/SP630/G
RUVAC RA	P2	-	3001	5001	7001	9001
RUVAC WA/WAU/WS/WSU	P2	2001	-	-	-	-
Backing pump SCREWLINE	P1	SP630	SP630	SP630	SP630	SP630
	DN ₁	160 ISO-K	250 ISO-K	250 ISO-K	250 ISO-K	320 ISO-K
	DN ₂	100 ISO-K	100 ISO-K	100 ISO-K	100 ISO-K	100 ISO-K
	l	2200 (86.62)	2200 (86.62)	2400 (94.49)	2400 (94.49)	2400 (94.49)
	l ₁	600 (23.62)	600 (23.62)	720 (28.35)	720 (28.35)	720 (28.35)
	l ₂	892 (35.12)	892 (35.12)	1012 (39.84)	1012 (39.84)	1012 (39.84)
	b	1064 (41.89)	1064 (41.89)	1129 (44.45)	1129 (44.45)	1129 (44.45)
	b ₁	400 (15.75)	400 (15.75)	465 (18.31)	465 (18.31)	465 (18.31)
	b ₂	554 (21.81)	554 (21.81)	554 (21.81)	554 (21.81)	554 (21.81)
	b ₃	800 (31.50)	800 (31.50)	930 (36.61)	930 (36.61)	930 (36.61)
	b ₄	70 (2.76)	70 (2.76)	-	-	-
	h	1789 (70.43)	2030 (79.92)	2220 (87.40)	2220 (87.40)	2300 (90.55)
	h ₁	1380 (54.33)	1380 (54.33)	1440 (56.69)	1440 (56.69)	1440 (56.69)
	h ₂	1259 (49.57)	1415 (55.71)	1475 (58.07)	1475 (58.07)	1475 (58.07)

¹⁾ Clearance for maintenance

Dimensional drawing of the pump systems with dry compressing SCREWLINE SP630 backing pump, frame version; dimensions in brackets () are in inch

Technical Data, 50 Hz

		RUTA RA				
		2001/SP630/G	3001/SP630/G	5001/SP630/G	7001/SP630/G	9001/SP630/G
RUVAC RA	P2	-	3001	5001	7001	9001
RUVAC (WA/WAU/WS/WSU possible)	P2	2001	-	-	-	-
Backing pump SCREWLINE	P1	SP630	SP630	SP630	SP630	SP630
Pumping speed, 50 Hz at 10^{-1} mbar (7.5×10^{-2} Torr)	$m^3 \times h^{-1}$ (cfm)	1780 (1050)	3280 (1930)	4510 (2660)	5940 (3500)	6920 (4070)
Ultimate total pressure without gas ballast	mbar (Torr)	$< 1 \times 10^{-3}$ ($< 7.5 \times 10^{-4}$)	$< 1 \times 10^{-3}$ ($< 7.5 \times 10^{-4}$)	$< 1 \times 10^{-3}$ ($< 7.5 \times 10^{-4}$)	$< 1 \times 10^{-3}$ ($< 7.5 \times 10^{-4}$)	$< 1 \times 10^{-3}$ ($< 7.5 \times 10^{-4}$)
Installed motor power	kW (hp)	22.5 (30.0)	26.0 (35.0)	30.0 (40.0)	33.5 (45.0)	37.0 (50.0)
Electrical power consumption at 10^{-1} mbar (7.5×10^{-2} Torr)	kW (hp)	11.7 (15.7)	12.2 (16.4)	12.6 (16.9)	13.0 (17.4)	13.5 (18.1)
Noise level to DIN 45 635 with silencer at 10^{-1} mbar (7.5×10^{-2} Torr)	dB(A)	79	81	79	82	80
Weight, total, approx.	kg (lbs)	1300 (2870)	1550 (3420)	1900 (4190)	2000 (4410)	2630 (5800)
Connecting flange						
Inlet port	DN ₁	160 ISO-K	250 ISO-K	250 ISO-K	250 ISO-K	320 ISO-K
Outlet port	DN ₂	100 ISO-K	100 ISO-K	100 ISO-K	100 ISO-K	100 ISO-K

Ordering Information

		RUTA RA				
		2001/SP630/G	3001/SP630/G	5001/SP630/G	7001/SP630/G	9001/SP630/G
RUVAC	P2	-	RA 3001	RA 5001	RA 7001	RA 9001
RUVAC (WA/WAU/WS/WSU possible)	P2	WAU 2001	-	-	-	-
Backing pump SCREWLINE	P1	SP630	SP630	SP630	SP630	SP630
Pump system, complete (adaptor version), frame mounted, with Roots vacuum pump RUVAC WAU		Part No. 500 741	-	-	-	-
RUVAC RA		-	Part No. 500 742	Part No. 500 743	Part No. 500 744	Part No. 500 745
with water-cooled vacuum pump SCREWLINE SP630 F		Part No. 501 201	Part No. 501 202	Part No. 501 203	Part No. 501 204	Part No. 501 205
Frequency inverter RUVATRONIC (see description in Section "Accessories")		RT 5/2001 Part No. 500 001 384	RT 5/3001 Part No. 500 001 385 ¹⁾	RT 5/5001 Part No. 500 001 386 ¹⁾	RT 5/7001 Part No. 500 001 387 ¹⁾	RT 5/9001 Part No. 500 001 388 ¹⁾

¹⁾ With this combination, continuous operation of the Roots pump is not possible at atmospheric pressure

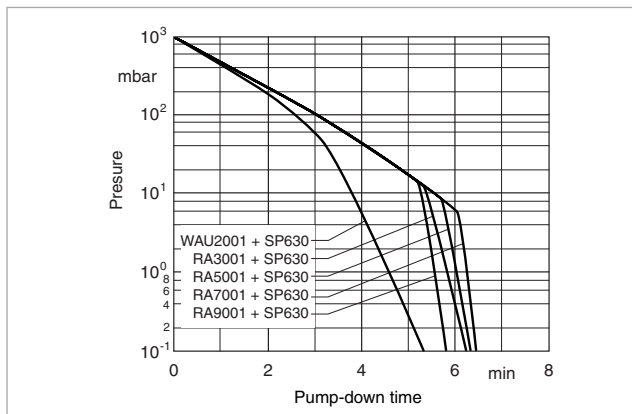

Pump-down time diagram for a 10 m³ tank at 50 Hz

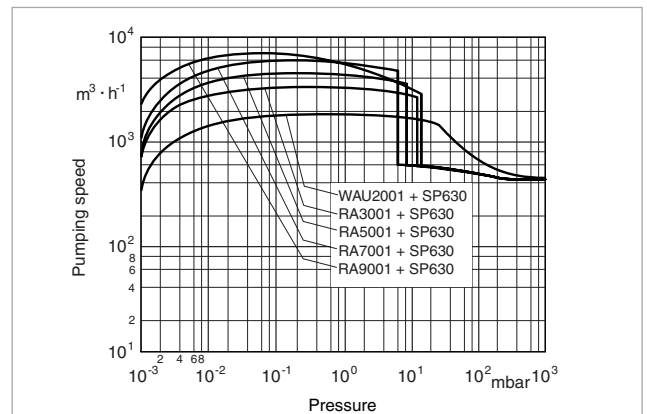

Pumping speed diagram at 50 Hz

RUVAC RAV Roots Vacuum Pumps with Pre-Admission Cooling

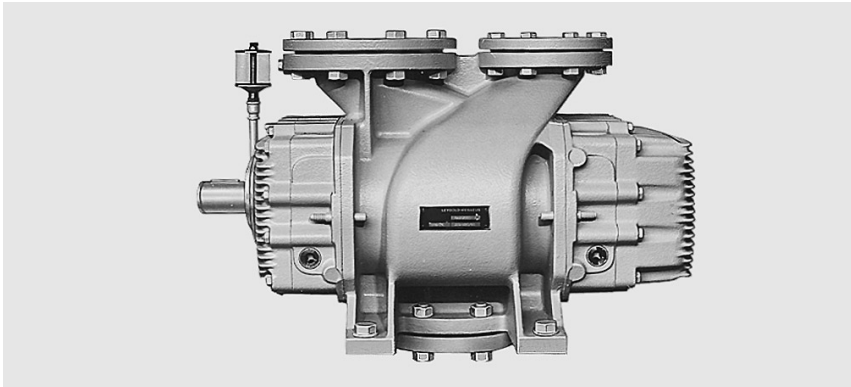

Typical Applications

- Short pump-down cycles on large volumes
- Oil-free compression of high volume flows of gases and vapors against atmospheric pressure
- Single-stage (G) or in combination with RAV F as backing pump
- Operating pressures in the rough vacuum range
- CE approval

Advantages to the User

- RUVAC RAV G

Operating pressure range of 150 mbar (112.5 Torr) against atmospheric pressure; total leak rate $< 10^{-1}$ mbar x l x s⁻¹ (7.5×10^{-2} Torr x l x s⁻¹)

- RUVAC RAV F

In combination with backing pumps the attainable operating pressures extend down into the medium vacuum range;

leak rate $< 10^{-2}$ mbar x l x s⁻¹ (7.5×10^{-3} Torr x l x s⁻¹)

- When series-connected the operating pressures extend down into the medium vacuum range:

- two-stages to 25 mbar (18.75 Torr)
- multiple stage to 10^{-3} mbar (7.5×10^{-4} Torr)

- Motors for special supply voltages and frequencies or protected types are available

- Pre-admission silencer and filter for the cooling gas inlet as well as silencers for the exhaust side (option/single-stage)
- Downstream gas cooler (option/multistage)
- C version (chemical version/option)
- Special materials (option)
- Pressure burst resistant version (option)

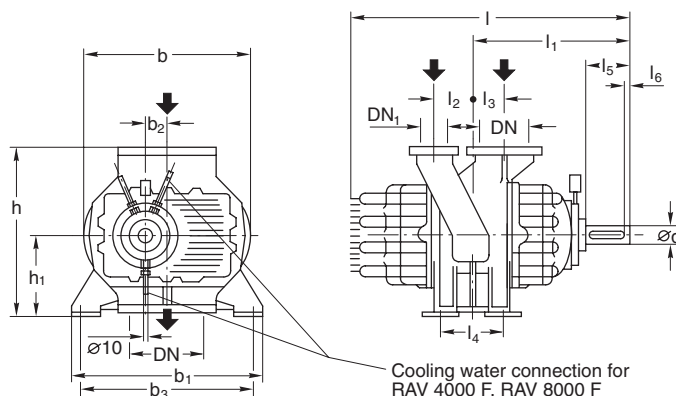

RUVAC RAV		DN		l	l ₁	l ₂	l ₃	l ₄	l ₅	l ₆	b	b ₁	b ₂	b ₃	Type F		Type G	
		DIN 2533	DIN 2533												d	d	h	h ₁
250 F/G	mm	80	50	529	283	90	100	125	50	5	321	332	34	300	25 k6	28 k6	313	132
	in.	80	50	20.83	11.14	3.54	3.94	4.92	1.97	0.20	12.64	13.07	1.34	11.81	0.98 k6	1.10 k6	12.32	5.20
500 F/G	mm	100	50	604	324	120	100	150	70	5	321	390	42.6	350	25 k6	38 k6	370	160
	in.	100	50	23.78	12.76	4.72	3.94	5.91	2.76	0.20	12.64	15.35	1.68	13.78	0.98 k6	1.50 k6	14.57	6.30
1000 F/G	mm	100	80	705	380	125	115	210	90	5	427	440	53.3	400	42 k6	45 k6	410	180
	in.	100	80	27.76	14.96	4.92	4.53	8.27	3.54	0.20	16.81	17.32	2.10	15.75	1.65 k6	1.77 k6	16.14	7.09
2000 F/G	mm	150	100	806	423	160	130	270	80	5	476	570	67.6	510	42 k6	55 k6	450	200
	in.	150	100	31.73	16.65	6.30	5.12	10.63	3.15	0.20	18.74	22.44	2.66	20.08	1.65 k6	2.17 k6	17.72	7.87
4000 F/G	mm	250 ¹⁾	150	1143	610	250	200	410	95	5	682	800	106	720	55 k6	70 m6	680	315
	in.	250 ¹⁾	150	45.0	24.02	9.84	7.87	16.14	3.74	0.20	26.85	31.50	4.17	28.35	2.17 k6	2.76 m6	26.77	12.40
8000 F/G	mm	300 ¹⁾	200 ¹⁾	1337	717	300	230	525	100	8	954	910	135	830	70 k6	90 m6	760	355
	in.	300 ¹⁾	200 ¹⁾	52.64	28.23	11.81	9.06	20.67	3.94	0.31	37.56	35.83	5.31	32.68	2.76 k6	3.54 m6	29.92	13.98

¹⁾ DIN 2532

DN₁ = Pre-inlet

Dimensional drawing for the RUVAC RAV pumps

Technical Data, 50 Hz

		RUVAC RAV					
		250 G	500 G	1000 G	2000 G	4000 G	8000 G
Pumping speed ¹⁾	m ³ x h ⁻¹ (cfm)	250 (147)	500 (295)	1000 (589)	2000 (1178)	3700 (2179)	8100 (4771)
Nominal speed	min ⁻¹ (rpm)	3000 (3000)	3000 (3000)	3000 (3000)	3000 (3000)	1500 (1500)	1500 (1500)
Max. permissible pressure difference ²⁾	mbar (Torr)	850 (637)	850 (637)	850 (637)	850 (637)	850 (637)	850 (637)
Connecting flange	DN	80	100	100	150	250	300
Max. permissible motor power	for direct drive						
	for belt drive						
	kW (hp)	11.0 (15.0)	18.5 (25.2)	30.0 (40.8)	55.0 (74.8)	95.0 (129.3)	200.0 (272.1)
	kW (hp)	11.0 (15.0)	18.5 (25.2)	30.0 (40.8)	55.0 (74.8)	95.0 (129.3)	200.0 (272.1)
Weight	kg (lbs)	95 (210)	160 (353)	225 (496)	310 (684)	720 (1588)	1230 (2712)

Ordering Information

		RUVAC RAV					
		250 G	500 G	1000 G	2000 G	4000 G	8000 G
Roots vacuum pump RUVAC RAV G		upon request	upon request	upon request	upon request	upon request	upon request

Technical Data, 50 Hz

		RUVAC RAV					
		250 F	500 F	1000 F	2000 F	4000 F	8000 F
Pumping speed ¹⁾	m ³ x h ⁻¹ (cfm)	250 (147)	500 (295)	1000 (589)	2000 (1178)	3700 (2179)	8100 (4771)
Nominal speed	min ⁻¹ (rpm)	3000 (3000)	3000 (3000)	3000 (3000)	3000 (3000)	1500 (1500)	1500 (1500)
Max. permissible pressure difference ²⁾	mbar (Torr)	850 (637)	850 (637)	850 (637)	850 (637)	850 (637)	850 (637)
Connecting flange	DN	80	100	100	150	250	300
Max. permissible motor power	for direct drive						
	for belt drive						
	kW (hp)	11.0 (15.0)	18.5 (25.2)	30.0 (40.8)	55.0 (74.8)	95.0 (129.3)	200.0 (272.1)
	kW (hp)	4.0 (5.4)	4.0 (5.4)	7.5 (10.2)	15.0 (20.4)	37.0 (50.3)	75 (102.0)
Gear oil, approx.	l (qt)	0.9 (0.95)	1.1 (1.6)	1.5 (1.59)	2.5 (2.64)	12.0 (12.68)	11.0 (11.63)
Weight, approx.	kg (lbs)	95 (210)	160 (353)	225 (496)	310 (684)	720 (1588)	1230 (2712)
Cooling water connection, fitting for tube		-	-	-	-	10 x 1	10 x 1
Cooling water requirement, approx.	l x h ⁻¹	-	-	-	-	60	60

Ordering Information

		RUVAC RAV					
		250 F	500 F	1000 F	2000 F	4000 F	8000 F
Roots vacuum pump RUVAC RAV F		upon request	upon request	upon request	upon request	upon request	upon request

¹⁾ To DIN 28 400 and following numbers

²⁾ RUVAC RAV G and RAV F with direct drive

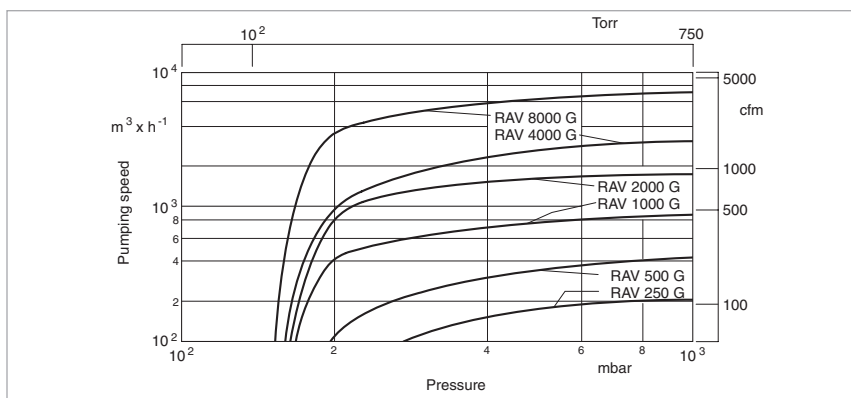

Pumping speed diagram of RUVAC RAV at 50 Hz

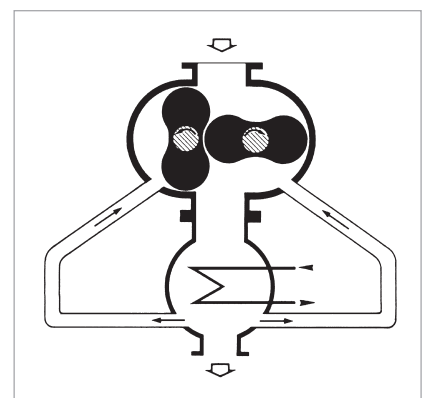

Operating diagram of RUVAC RAV vacuum pumps with pre-admission cooling

RUTA RAV Pump Systems with RUVAC RAV Roots Vacuum Pumps, Two-Stage

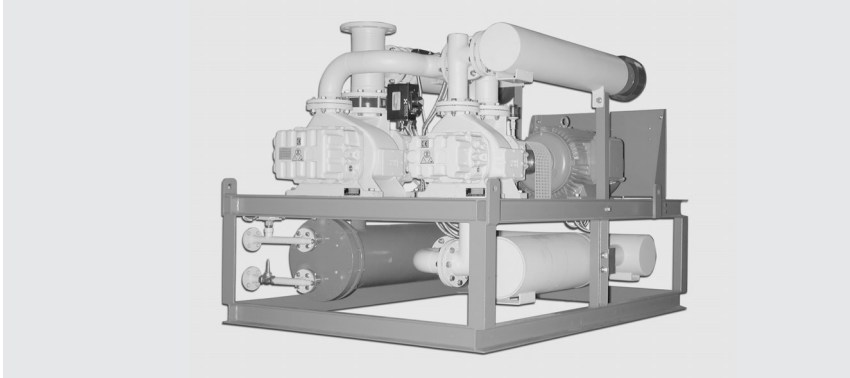

Standard Equipment

- Roots vacuum pumps with pre-admission cooling
- One or two RAV F pumps are connected upstream of the RUVAC RAV G pump operating as a backing pump
- CE approval
- Ultimate pressures below 50 mbar (37.5 Torr) can be attained
- Gas cooler, pre-admission silencer and filter
- Non-return flap
- Exhaust silencer

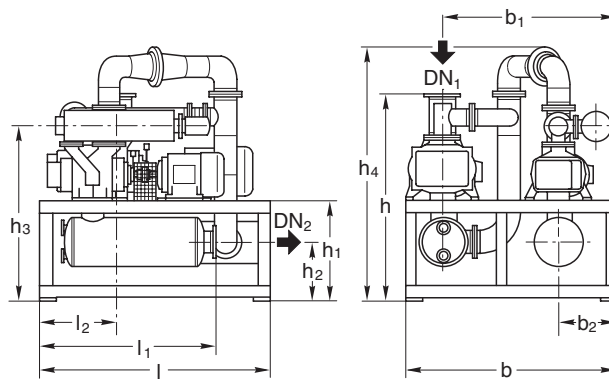

	RUTA	500 F/250 G	1000 F/500 G	2000 F/1000 G	4000 F/2000 G	8000 F/4000 G
RUVAC RAV	P2	500 F	1000 F	2000 F	4000 F	8000 F
RUVAC RAV	P1	250 G	500 G	1000 G	2000 G	4000 G
	DN ₁	100 (3.94)	100 (3.94)	150 (5.91)	250 (9.84)	300 (11.81)
	DN ₂	80 (3.15)	100 (3.94)	100 (3.94)	150 (5.91)	250 (9.84)
	l	1290 (50.79)	1560 (61.42)	1830 (72.03)	2400 (94.49)	2790 (109.84)
	l ₁	420 (16.54)	480 (18.90)	570 (22.44)	800 (31.50)	950 (37.40)
	l ₂	1050 (41.34)	1100 (43.31)	1300 (51.18)	1650 (64.96)	2150 (84.65)
	b	1300 (51.18)	1500 (59.06)	1680 (66.14)	2050 (80.71)	2600 (102.36)
	b ₁	1050 (41.34)	1180 (46.46)	1300 (51.18)	1550 (61.02)	2100 (82.68)
	b ₂	400 (15.75)	400 (15.75)	450 (17.72)	500 (19.69)	700 (27.56)
	h	1550 (61.02)	1700 (66.93)	1930 (75.98)	2550 (100.39)	3100 (122.05)
	h ₁	720 (28.35)	820 (32.28)	1000 (39.37)	1100 (43.31)	1200 (47.24)
	h ₂	500 (19.69)	570 (22.44)	750 (29.53)	700 (27.56)	700 (27.56)
	h ₃	1180 (46.46)	1340 (52.76)	1540 (60.63)	1750 (68.90)	2100 (82.68)
	h ₄	1370 (53.94)	1520 (59.84)	1750 (68.90)	2210 (87.01)	2500 (98.43)

Dimensional drawing for two-stage RUTA RAV pump systems; dimensions in brackets () are in inch

Technical Data, 50 Hz

RUTA RAV

		500 F/ 250 G	1000 F/ 500 G	2000 F/ 1000 G	4000 F/ 2000 G	8000 F/ 4000 G
RUVAC RAV	P2	500 F	1000 F	2000 F	4000 F	8000 F
RUVAC RAV	P1	250 G	500 G	1000 G	2000 G	4000 G
Pumping speed, 50 hz						
at 200 mbar (150 Torr)	m ³ x h ⁻¹ (cfm)	322.0 (189.7)	708.0 (417.0)	1518.0 (894.1)	2685.0 (1581.5)	5821.0 (3428.6)
at 100 mbar (75 Torr)	m ³ x h ⁻¹ (cfm)	–	–	–	–	–
Ultimate total pressure (other motors are required)	mbar (Torr)	< 50.0 (< 37.5)	< 50.0 (< 37.5)	< 50.0 (< 37.5)	< 50.0 (< 37.5)	< 50.0 (< 37.5)
Cut-in pressure						
P2 ¹⁾	mbar (Torr)	576.0 (432.0)	538.0 (403.5)	548.0 (411.0)	630.0 (472.5)	502.0 (376.5)
P1	mbar (Torr)	1013.0 (760.0)	1013.0 (760.0)	1013.0 (760.0)	1013.0 (760.0)	1013.0 (760.0)
Installed motor power	kW (hp)	15.0 (20.4)	22.0 (29.9)	44.0 (59.9)	82.0 (111.6)	165.0 (224.5)
Power consumption at 200 mbar (150 Torr)	kW (hp)	7.8 (10.6)	15.8 (21.5)	31.5 (42.9)	56.4 (76.7)	122.0 (166.0)
Cooling water consumption (T < 30°, ΔT < 10 K), max. (gas coolers and pumps)	m ³ x h ⁻¹ (cfm)	0.5 (0.3)	1.0 (0.6)	2.0 (1.2)	3.0 (1.8)	7.0 (4.1)
Noise level to DIN 45 635 with pre-inlet and pulsation silencers and pump exhaust leading outside plus additional sound proofing box	dB(A)	86	88	93	104	106
(a further reduction is possible)	dB(A)	72	74	80	84	86
Gear oil, approx.	l (qt)	2.0 (2.11)	2.5 (2.64)	4.0 (4.23)	14.5 (15.33)	23.0 (24.31)
Total weight, incl. silencers for pre- admission and exhaust, approx.	kg (lbs)	1000 (2205)	1600 (3528)	2200 (4851)	4000 (8820)	7500 (16538)
Connecting flange (pipe connection) ²⁾						
Inlet port	DN ₁	100	100	150	250	300
Outlet port	DN ₂	80	100	100	150	250
Gas admission port without filter	DN	50	50	80	100	150

Ordering Information

RUTA RAV

	500 F/ 250 G	1000 F/ 500 G	2000 F/ 1000 G	4000 F/ 2000 G	8000 F/ 4000 G
Pump system	upon request	upon request	upon request	upon request	upon request

¹⁾ With exhaust flap and bypass line 1013 mbar (760 Torr)

²⁾ to DIN 25 33

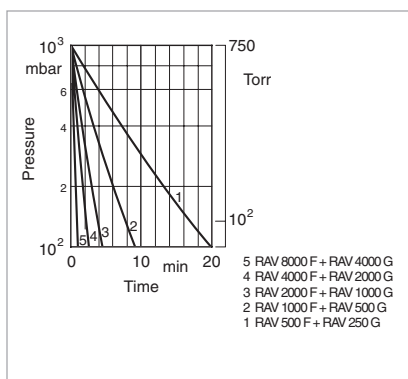

Pump-down time diagram for a 50 m³ tank
for RAV F+G at 50 Hz

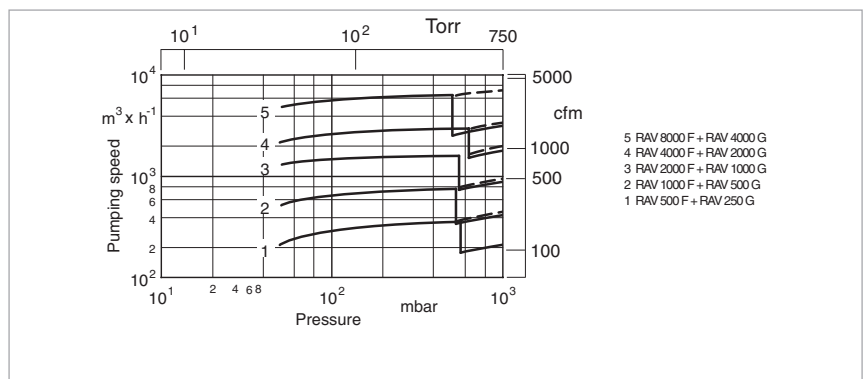

Pumping speed diagram of RAV F + G at 50 Hz

RUTA RAV Pump Systems with RUVAC RAV Roots Vacuum Pumps, Three-Stage

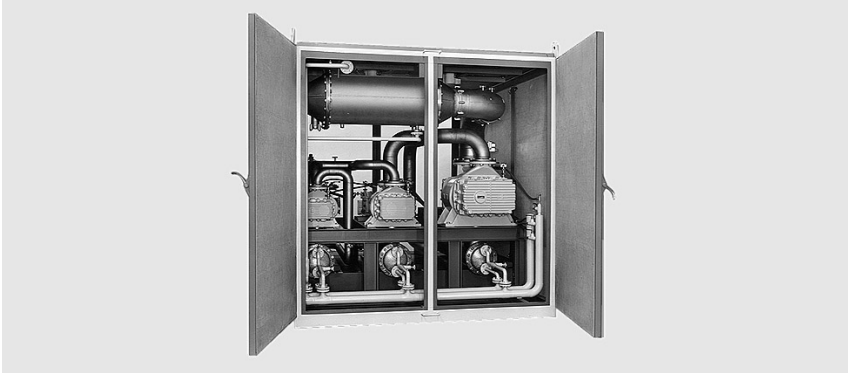

Standard Equipment

- Roots vacuum pumps with pre-admission cooling
- Two RAV F pumps are connected upstream of the RUVAC RAV G pump operating as a backing pump
- CE approval
- Ultimate pressures below 10 mbar (7.5 Torr) can be attained
- Gas cooler, pre-admission silencer and filter
- Non-return flap
- Exhaust silencer

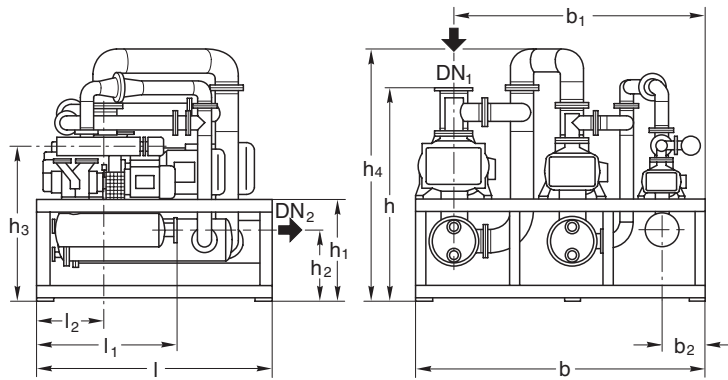

	RUTA	1000 F/500 F/250 G	2000 F/1000 F/500 G	4000 F/2000 F/1000 G	8000 F/4000 F/2000 G
RUVAC RAV	P3	1000 F	2000 F	4000 F	8000 F
RUVAC RAV	P2	500 F	1000 F	2000 F	4000 F
RUVAC RAV	P1	250 G	500 G	1000 G	2000 G
	DN ₁	100 (3.94)	150 (5.91)	250 (9.84)	300 (11.81)
	DN ₂	80 (3.15)	100 (3.94)	100 (3.94)	150 (5.91)
	l	1560 (61.42)	1830 (72.05)	2400 (94.49)	2790 (109.84)
	l ₁	480 (18.90)	570 (22.44)	800 (31.50)	950 (37.40)
	l ₂	1050 (41.34)	1100 (43.31)	1350 (53.15)	1650 (64.96)
	b	2170 (85.43)	2400 (94.49)	2850 (112.20)	3400 (133.86)
	b ₁	1850 (72.83)	2000 (78.74)	2400 (94.49)	2950 (116.14)
	b ₂	400 (15.75)	400 (15.75)	450 (17.72)	500 (19.69)
	h	1720 (67.72)	1950 (76.77)	2550 (100.39)	3000 (118.11)
	h ₁	800 (31.5)	1000 (39.37)	1150 (45.28)	1200 (47.24)
	h ₂	600 (23.62)	750 (29.53)	850 (33.46)	850 (33.46)
	h ₃	1280 (50.39)	1500 (59.06)	1700 (66.93)	1830 (72.05)
	h ₄	1520 (59.84)	1750 (68.90)	2210 (87.01)	2500 (98.43)

Dimensional drawing for three-stage RUTA RAV pump systems; dimensions in brackets () are in inch

Technical Data, 50 Hz

RUTA RAV

		1000 F/ 500 F/ 250 G	2000 F/ 1000 F/ 500 G	4000 F/ 2000 F/ 1000 G	8000 F/ 4000 F/ 2000 G
RUVAC RAV	P3	1000 F	2000 F	4000 F	8000 F
RUVAC RAV	P2	500 F	1000 F	2000 F	4000 F
RUVAC RAV	P1	250 G	500 G	1000 G	2000 G
Pumping speed, 50 Hz					
at 200 mbar (150 Torr)	m ³ x h ⁻¹ (cfm)	–	–	–	–
at 100 mbar (75 Torr)	m ³ x h ⁻¹ (cfm)	741.0 (436.4)	1573.0 (926.5)	2862.0 (1685.7)	6243.0 (3677.1)
Ultimate total pressure (other motors are required)		mbar (Torr)	< 10.0 (< 7.5)	< 10.0 (< 7.5)	< 10.0 (< 7.5)
Cut-in pressure					
P3 ¹⁾	mbar (Torr)	278.0 (208.5)	265.0 (198.8)	312.0 (234.0)	289.0 (216.8)
P2 ¹⁾	mbar (Torr)	576.0 (432.0)	538.0 (403.5)	548.0 (411.0)	630.0 (472.5)
P1	mbar (Torr)	1013.0 (760.0)	1013.0 (760.0)	1013.0 (760.0)	1013.0 (760.0)
Installed motor power		kW (hp)	22.5 (30.6)	37.0 (50.3)	62.5 (85.0)
Power consumption at 100 mbar (75 Torr)		kW (hp)	12.0 (16.3)	24.4 (33.2)	42.3 (57.6)
Cooling water consumption (T < 30°, ΔT < 10 K), max. (gas coolers and pumps)		m ³ x h ⁻¹ (cfm)	1.0 (0.6)	2.0 (1.2)	4.0 (2.4)
Noise level to DIN 45 635 with pre-inlet and pulsation silencers and pump exhaust leading outside plus additional sound proofing box					
	dB(A)	88	95	106	108
	dB(A)	75	77	86	88
(a further reduction is possible)					
Gear oil, approx.		l (qt)	3.5 (3.70)	5.0 (5.29)	16.0 (16.91)
Total weight, incl. silencers for pre- admission and exhaust, approx.		kg (lbs)	2000 (4410)	3000 (6615)	5000 (11025)
Connecting flange (pipe connection) ²⁾					
Inlet port	DN ₁	100	150	250	300
Outlet port	DN ₂	80	100	100	150
Gas admission port without filter	DN	50	50	80	100

Ordering Information

RUTA RAV

	1000 F/ 500 F/ 250 G	2000 F/ 1000 F/ 500 G	4000 F/ 2000 F/ 1000 G	8000 F/ 4000 F/ 2000 G
Pump system	upon request	upon request	upon request	upon request

¹⁾ With exhaust flap and bypass line 1013 mbar (760 Torr)

²⁾ to DIN 25 33

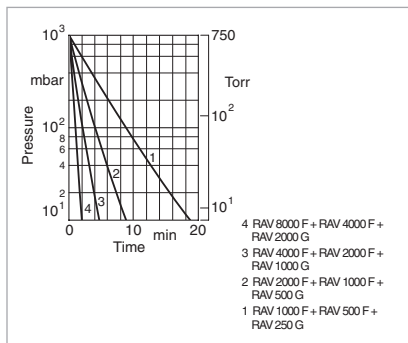

Pump-down time diagram for a 50 m³ tank for RAV F, F + G at 50 Hz

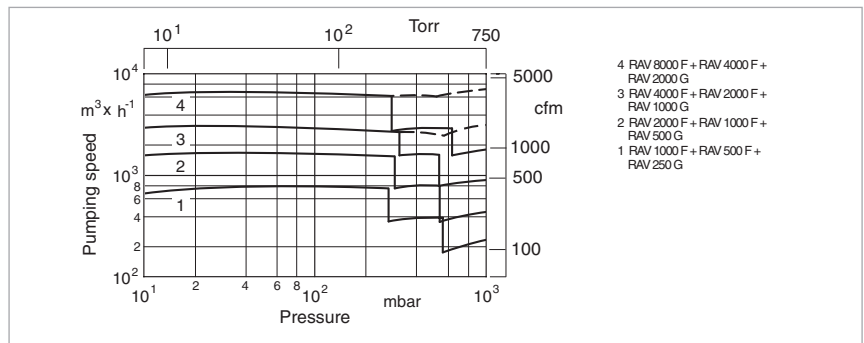

Pumping speed diagram of RAV F, F + G at 50 Hz

TVD Pump Systems for Drying, Evaporation and Distillation Applications

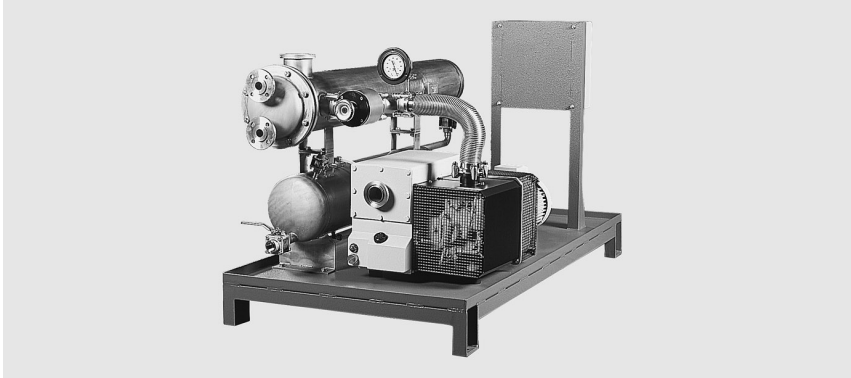

TVD 200

Advantages to the User

- Operating agent may be reused, for example by returning cleaned water to the process
- Reduction of the quantities which need to be disposed of by 80%
- Low temperature distillation/drying
- Condensate may be drained during vacuum operation
- CE approval

Typical Applications

- Drying of powders and solids, for example
- Cleaning of waste water
- Vacuum distillation

Standard Equipment

- Condenser at the intake side
- Receiver with condensate level indicator
- Manually operated valves on the receiver
- SOGEVAC rotary vane pump with integrated exhaust filters, anti-suckback valve and gas ballast valve

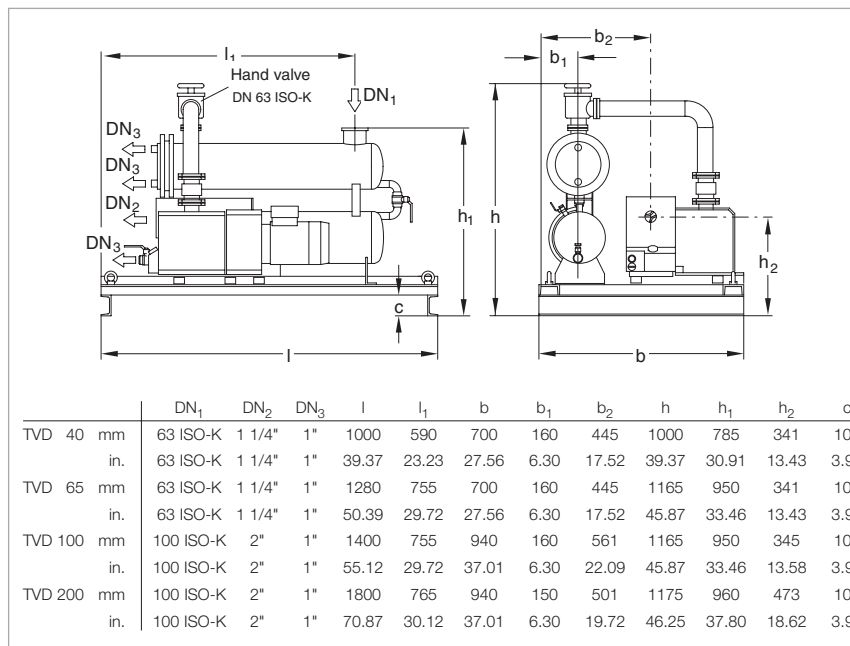

Dimensional drawing for the TVD pump systems

Options

- Valve between condenser and rotary vane pump
- Pressure gauge for checking the condensate pressure
- Solenoid valves at the receiver
- Receiver with proximity switch for monitoring the condensate level
- Electric control for automatic operation of the pump system
- Mobile pallet with castors
- Cold water replacement for mobile applications

Technical Data, 50 Hz**TVD 40****TVD 65****TVD 100****TVD 200**

Condenser, effective surface area, approx.	m ²	1	2	3	5
Receiver, usable volume	l (qt)	30.0 (31.71)	50.0 (52.85)	50.0 (52.85)	50.0 (52.85)
Rotary vane vacuum pump	SOGEVAC	SV 40	SV 65	SV 100	SV 200
Nominal pumping speed	m ³ x h ⁻¹ (cfm)	46.0 (27.1)	65.0 (38.3)	100.0 (58.9)	180.0 (106.0)
Pumping speed at 50 Hz for air	m ³ x h ⁻¹ (cfm)	46.0 (27.1)	53.0 (31.2)	94.0 (55.4)	170.0 (100.1)
for water vapor at 50 mbar (37.5 Torr)	m ³ x h ⁻¹ (cfm)	280.0 (165.0)	560.0 (330.0)	840.0 (495.0)	1400.0 (825.0)
Ultimate total pressure with standard gas ballast	mbar (Torr)	< 1.5 (< 1.1)	< 1.5 (< 1.1)	< 1.5 (< 1.1)	< 0.7 (< 0.53)
Noise level to DIN 45 635 ¹⁾	dB(A)	63	64	70	69
Condensing capacity for water	l x h ⁻¹	10	20	30	50
Installed motor power	kW (hp)	1.1 (1.5)	1.5 (2.0)	2.2 (3.0)	4.0 (4.2)

¹⁾ Operating at ultimate pressure with gas ballast

Technical Data, 50 Hz**SV 40****SV 65****SV 100****SV 200**

Weight (with oil filling), approx.	kg (lbs)	125 (276)	150 (331)	200 (441)	300 (662)
Oil filling	l (qt)	2.0 (2.11)	2.0 (2.11)	3.5 (3.70)	5.0 (5.29)
Connecting flanges					
Inlet port	DN ₁	63 ISO-K	63 ISO-K	100 ISO-K	100 ISO-K
Outlet port	DN ₂	1 1/4"	1 1/4"	2"	2"

Ordering Information**TVD 40****TVD 65****TVD 100****TVD 200**

Pump system	Part No. 021 01	Part No. 021 02	Part No. 021 03	Part No. 021 04
-------------	------------------------	------------------------	------------------------	------------------------

Pump Systems (Only available for purchase in North and South America)

RBS - B/BCS Roots Pump Systems with Two-Stage TRIVAC Backing Pumps



RBS - B/BCS Roots pumping system, shown with optional AF exhaust filter

Standard Equipment

- System consists of TRIVAC dual stage B or BCS direct drive vane pump and RUVAC blower
- Complete air cooled system
- 18" wide frame base equipped with caster wheels and leveling pads
- Compact construction with quiet operation
- Manual operation of gas ballast
- Close-coupled RUVAC blower with ANSI inlet lange

Options

- All TRIVAC accessories, Exhaust filter, 24 V DC gas ballast valve, chemical oil filter, and electrical limit switch system
- Full frame drip pan
- Oil drain valves
- Special motor voltages and frequencies
- Special oil for unique applications
- Full electrical controls for control start/stop and monitoring of system

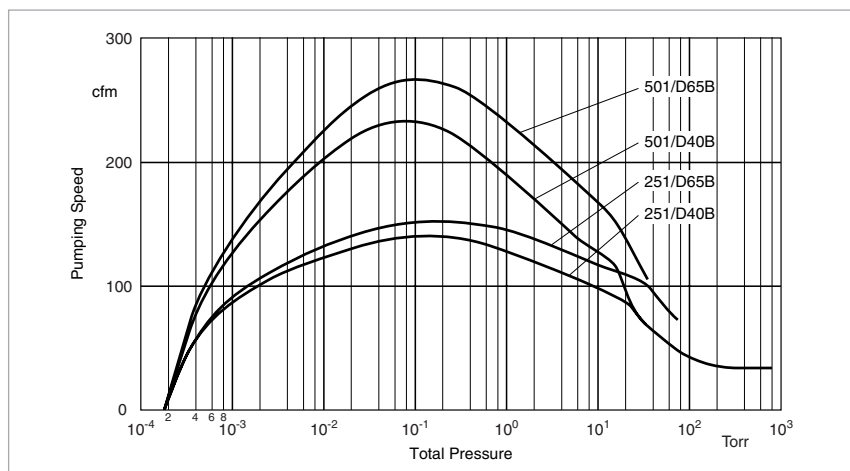

Pumping speed diagram for the RBS systems with WSU series Roots blowers at 60 Hz

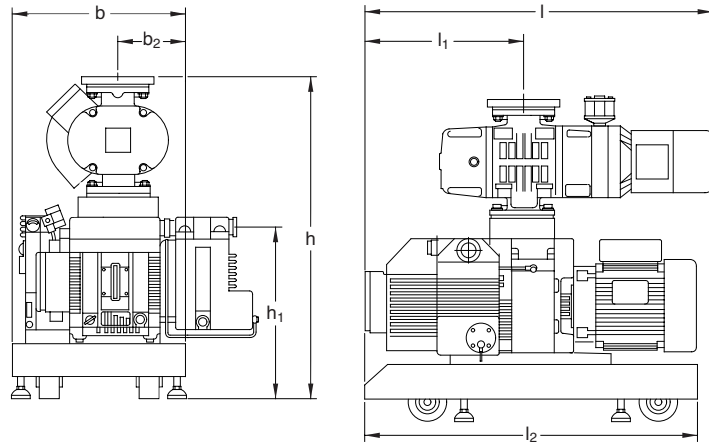

System	b	b ₁	b ₂	h	h ₁	l	l ₁	l ₂
Close-coupled								
D 40 B/BCS								
WSU 251	18 (457)	8 (203)	7 (178)	33 3/16 (853)	17 15/16 (456)	32 3/4 (832)	14 (356)	34 (864)
WSU 501	18 (457)	8 (203)	7 (178)	34 3/4 (883)	17 15/16 (456)	33 13/16 (859)	14 (356)	34 (864)
D 65 B/BCS								
WS/WSU 251	18 (457)	8 (203)	7 (178)	33 3/16 (853)	17 15/16 (456)	34 3/4 (883)	16 (406)	34 (864)
WS/WSU 501	18 (457)	8 (203)	7 (178)	34 3/4 (883)	17 15/16 (456)	35 13/16 (910)	16 (406)	34 (864)

Dimensional drawing for the RBS - B/BCS Roots pumping systems 18" with TRIVAC D 40/65 B backing pumps, close-coupled package; dimensions in brackets () are in mm

RBS - B/BCS Roots Pump Systems

Technical Data

		251/D40B	251/D65B	501/D40B	501/D65B
RUVAC (WA/WAU/WS/WSU possible)		251	251	501	501
TRIVAC backing pump		D 40 B/BCS	D 65 B/BCS	D 40 B/BCS	D 65 B/BCS
Pumping speed @ 0.1 Torr	cfm (m ³ x h ⁻¹)	140 (237)	150 (254)	232 (394)	267 (453)
Ultimate total pressure	Torr (mbar)	2 x 10 ⁻⁴ (< 4 x 10 ⁻⁴)	2 x 10 ⁻⁴ (< 4 x 10 ⁻⁴)	2 x 10 ⁻⁴ (< 4 x 10 ⁻⁴)	2 x 10 ⁻⁴ (< 4 x 10 ⁻⁴)
Connecting flanges					
Inlet port					
WSU	DN	3" ANSI	3" ANSI	3" ANSI	3" ANSI
Outlet port	DN	40 ISO-KF	40 ISO-KF	40 ISO-KF	40 ISO-KF
Operating voltage	V	208/230/460	208/230/460	208/230/460	208/230/460
Phase / Frequency ¹⁾	- / Hz	3 / 60	3 / 60	3 / 60	3 / 60
Full load amps ²⁾					
RUVAC WSU		5.5/5.5/3.2	5.5/5.5/3.2	9.0/9.0/5.2	9.0/9.0/5.2
TRIVAC		9.0/8.8/4.5	9.0/8.8/4.5	9.0/8.8/4.5	9.0/8.8/4.5
Displacement					
RUVAC	cfm (m ³ x h ⁻¹)	179 (304)	179 (304)	357 (606)	357 (606)
TRIVAC	cfm (m ³ x h ⁻¹)	32 (54)	53 (90)	32 (54)	53 (90)
Maximum differential pressure	Torr (mbar)	60 (80)	60 (80)	60 (80)	60 (80)
Normal starting pressure ³⁾	Torr (mbar)	20 (27)	30 (40)	12 (16)	16 (21)
Oil capacity					
RUVAC WSU	qt (l)	0.75 (0.7)	0.75 (0.7)	1.10 (1.0)	1.10 (1.0)
TRIVAC	qt (l)	2.70 (2.6)	3.40 (3.2)	2.70 (2.6)	3.40 (3.2)
Nominal rotation speed					
RUVAC	rpm (min ⁻¹)	3600 (3600)	3600 (3600)	3600 (3600)	3600 (3600)
TRIVAC	rpm (min ⁻¹)	1800 (1800)	1800 (1800)	1800 (1800)	1800 (1800)
Motor power					
RUVAC WSU	hp (kW)	1.9 (1.4)	1.9 (1.4)	3.3 (2.4)	3.3 (2.4)
TRIVAC	hp (kW)	3.0 (2.2)	3.0 (2.2)	3.0 (2.2)	3.0 (2.2)

RBS - B/BCS Roots Pump Systems

Ordering Information

	251/D40B	251/D65B	501/D40B	501/D65B
RBS - B/BCS Roots pump system (supplied with hydrocarbon oil)	Ordering Information see right page			

¹⁾ For 50 Hz systems, consult the factory

²⁾ Determined by operating voltage

³⁾ WSU pumps permit start-up at atmospheric pressure (760 Torr)

Ordering Information

Blower / TRIVAC pump
WSU 251 / D 40 B
WSU 251 / D 40 BCS-PFPE
WSU 251 / D 65 B
WSU 251 / D 65 B-PFPE
WSU 501 / D 40 B
WSU 501 / D 40 BCS-PFPE
WSU 501 / D 65 B
WSU 501 / D 65 BCS-PFPE
Reserved
Electrical Control Panel
None
208 V
230 V
460 V

Part No. 180037V-

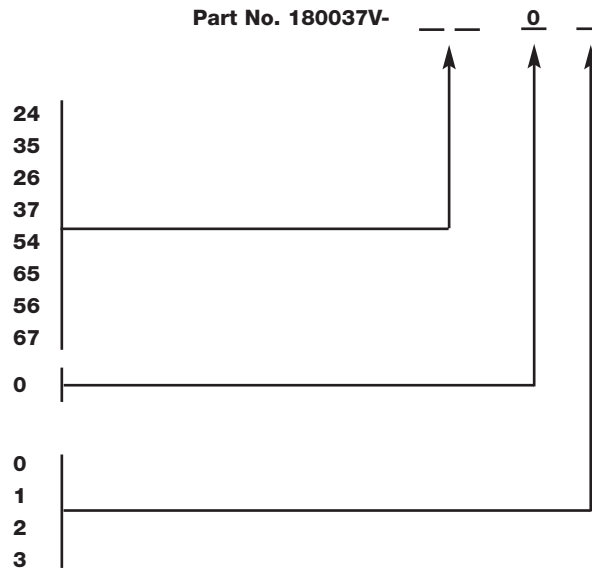

Pump Systems (Only available for purchase in North and South America)

HTS Close-Coupled Systems with Single-Stage SOGEVAC Backing Pumps

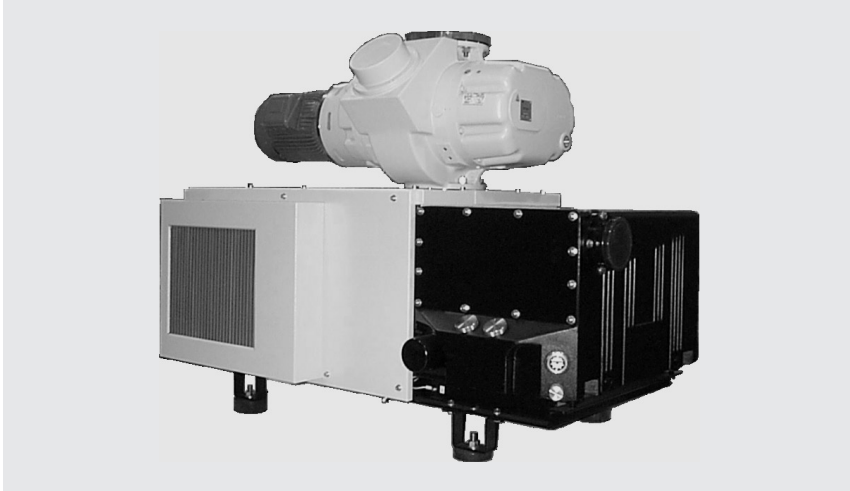

HTS close-coupled system

Standard Equipment

- System consists of single stage SOGEVAC vane pump
- Complete air cooled system
- Close-coupled RUVAC blower
- Compact construction with quiet operation
- Manual operation of gas ballast
- Spin-on type oil filter

Options

- SOGEVAC accessories: oil level monitoring, exhaust case gauge, 24 V DC gas ballast purge, water-cooling
- Frame base mounted caster wheels
- Frame base mounted leveling pads
- Oil drain valves
- Inlet dust filter

- External OF3000 oil filter
- Special motor voltages and frequencies
- Special oil for unique applications
- Full NEMA12 electrical controls for stand/stop operation and monitoring of system from remote and local locations
- 24 V DC gas ballast valve

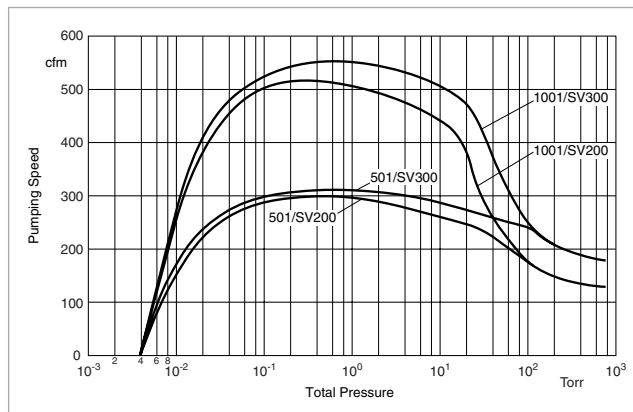

Pumping speed diagram for the HTS close-coupled systems with WSU series Roots blowers and SOGEVAC SV 200/300 at 60 Hz

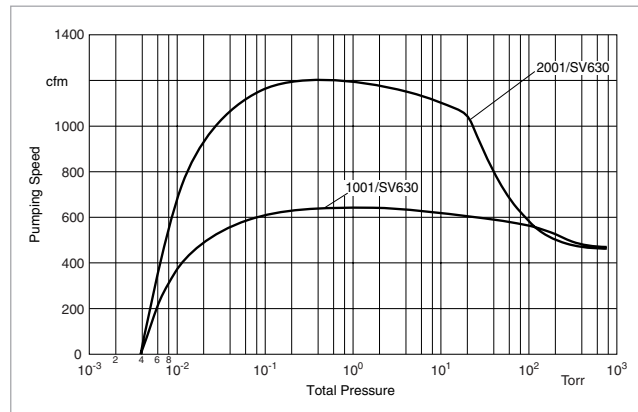

Pumping speed diagram for the HTS close-coupled systems with WSU series Roots blowers and SOGEVAC SV 630 at 60 Hz

Dimensions for SV 200 and SV 300 only

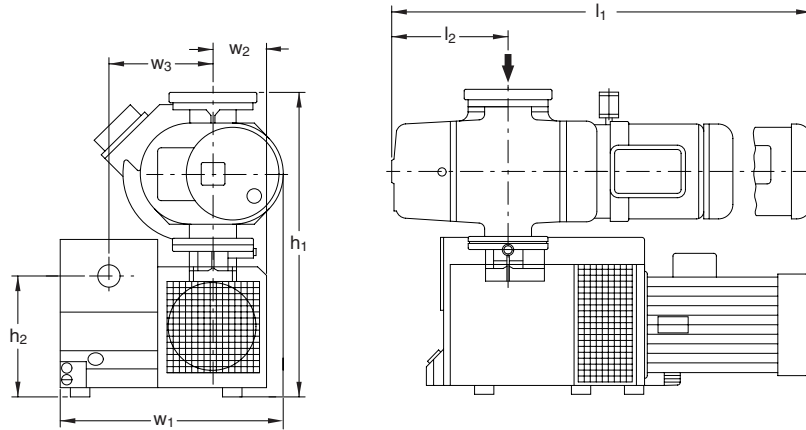

Dimensions for SV 630 only

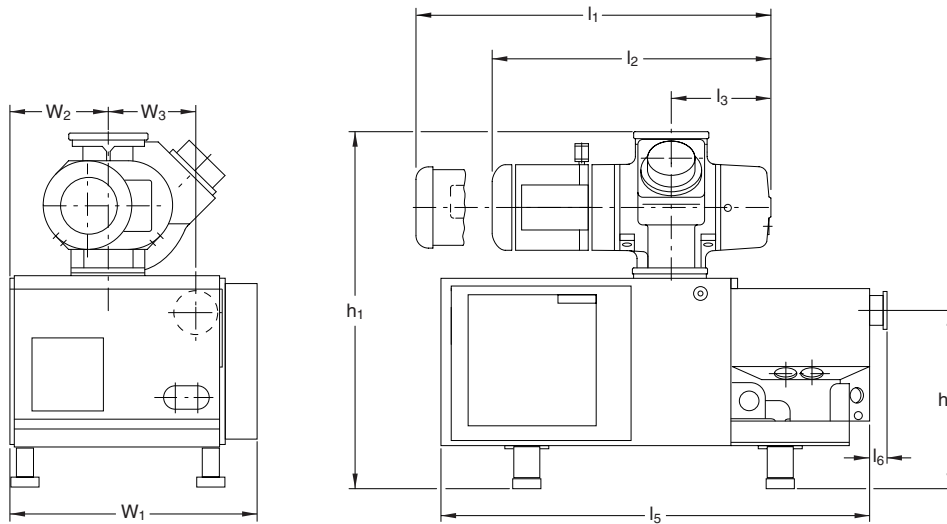

Roots Pump	Vane Pump	h_1	h_2	l_1	l_2	l_3	l_5	l_6	w_1	w_2	w_3
WSU 501	SV 200	29 7/16 (748)	12 17/32 (318)	-	9 17/32 (242)	-	-	-	21 11/16 (551)	6 1/8 (156)	10 19/32 (269)
WSU 501	SV 300	29 7/16 (748)	12 17/32 (318)	-	9 17/32 (242)	-	-	-	21 11/16 (551)	6 1/8 (156)	10 19/32 (269)
WSU 1001	SV 200	31 7/16 (799)	12 17/32 (318)	-	11 15/16 (303)	-	-	-	21 1/16 (535)	5 1/2 (140)	10 19/32 (269)
WSU 1001	SV 300	31 7/16 (799)	12 17/32 (318)	-	11 15/16 (303)	-	-	-	22 13/16 (579)	7 1/4 (184)	10 19/32 (269)
WSU 2001	SV 630	48 5/16 (1227)	23 13/16 (605)	50 3/16 (1275)	-	14 9/16 (370)	60 3/4 (1543)	2 1/2 (64)	34 15/16 (887)	13 7/8 (352)	12 13/32 (315)

Dimensional drawing for the HTS close-coupled system with single-stage SOGEVAC backing pumps; dimensions in brackets () are in mm

Technical Data

HTS Close-Coupled Systems

		501/SV200	501/SV300	1001/SV200	1001/SV300
RUVAC		WSU 501	WSU 501	WSU 1001	WSU 1001
SOGEVAC		SV 200	SV 300	SV 200	SV 300
Pumping speed @ 0.1 Torr	cfm (m ³ x h ⁻¹)	277 (470)	285 (483)	504 (855)	545 (925)
Ultimate total pressure	Torr (mbar)	< 8 x 10 ⁻³ (< 1 x 10 ⁻²)	< 8 x 10 ⁻³ (< 1 x 10 ⁻²)	< 8 x 10 ⁻³ (< 1 x 10 ⁻²)	< 8 x 10 ⁻³ (< 1 x 10 ⁻²)
Connecting flanges					
Inlet port WSU	DN	3" ANSI	3" ANSI	4" ANSI	4" ANSI
Exhaust port SOGEVAC	DN	2" NPT	2" NPT	2" NPT	2" NPT
Operating voltage	V	208/230/460	208/230/460	208/230/460	208/230/460
Phase / Frequency ¹⁾	- / Hz	3 / 60	3 / 60	3 / 60	3 / 60
Full load amps ²⁾					
RUVAC WSU		7.8/10.0/5.8	7.8/10.0/5.8	13.0/14.7/8.5	13.0/14.7/8.5
SOGEVAC		21.0/18.0/9.0	29.0/25.0/12.5	21.0/18.0/9.0	29.0/25.0/12.5
Displacement					
RUVAC	cfm (m ³ x h ⁻¹)	357 (606)	357 (606)	707 (1200)	707 (1200)
SOGEVAC	cfm (m ³ x h ⁻¹)	130 (606)	200 (340)	130 (606)	200 (340)
Oil capacity					
RUVAC WSU	qt (l)	1.10 (1.00)	1.10 (1.00)	2.10 (2.00)	2.10 (2.00)
SOGEVAC	qt (l)	5.30 (5.00)	9.00 (8.50)	5.30 (5.00)	9.00 (8.50)
Nominal rotation speed					
RUVAC WAU/WSU	rpm (min ⁻¹)	3600 (3600)	3600 (3600)	3600 (3600)	3600 (3600)
SOGEVAC	rpm (min ⁻¹)	1800 (1800)	1800 (1800)	1800 (1800)	1800 (1800)
Motor power					
RUVAC WSU	hp (kW)	3.3 (2.4)	3.3 (2.4)	6.0 (4.4)	6.0 (4.4)
SOGEVAC	hp (kW)	7.5 (5.5)	10.0 (7.4)	7.5 (5.5)	10.0 (7.4)

Ordering Information

HTS Close-Coupled Systems

	501/SV200	501/SV300	1001/SV200	1001/SV300
HTS - close-coupled systems	Ordering Information see right page			

¹⁾ For 50 Hz systems, consult the factory

²⁾ Determined by operating voltage

Technical Data

HTS Close-Coupled Systems

		1001/SV630	2001/SV630
RUVAC		1001	2001
SOGEVAC		SV 630	SV 630
Pumping speed @ 0.1 Torr	cfm (m ³ x h ⁻¹)	610 (1035)	1186 (2031)
Ultimate total pressure	Torr (mbar)	< 8 x 10 ⁻³ (< 1 x 10 ⁻²)	< 8 x 10 ⁻³ (< 1 x 10 ⁻²)
Connecting flanges			
Inlet port WSU	DN	4" ANSI	6" ANSI
Outlet port	DN	4" ANSI	4" ANSI
Operating voltage	V	460	460
Phase / Frequency ¹⁾	- / Hz	3 / 60	3 / 60
Full load amps ²⁾			
RUVAC WSU		8.5	5.0
SOGEVAC		29.5	29.5
Displacement			
RUVAC	cfm (m ³ x h ⁻¹)	707 (1200)	1449 (2460)
SOGEVAC	cfm (m ³ x h ⁻¹)	495 (840)	495 (840)
Oil capacity			
RUVAC WSU	qt (l)	2.10 (2.0)	4.20 (4.0)
SOGEVAC	qt (l)	37.0 (35.0)	37.0 (35.0)
Nominal rotation speed			
RUVAC WSU	rpm (min ⁻¹)	3600 (3600)	3600 (3600)
SOGEVAC	rpm (min ⁻¹)	1170 (1170)	1170 (1170)
Motor power			
RUVAC WSU	hp (kW)	6.1 (4.5)	11.4 (8.4)
SOGEVAC	hp (kW)	25.0 (13.4)	25.0 (13.4)

Ordering Information

Blower / TRIVAC pump

WSU 501 / SV 200
 WSU 501 / SV 300
 WSU 1001 / SV 200
 WSU 1001 / SV 300
 WSU 1001 / SV 630
 WSU 2001 / SV 630

Casters & Levelers (SV 200 & SV 300 only)

None
 Casters & Levelers
 Casters only
 Levelers only

Electrical Control Panel

None
 208 V (SV 200 & SV 300 only)
 230 V (SV 200 & SV 300 only)
 460 V

Part No. 180036V-

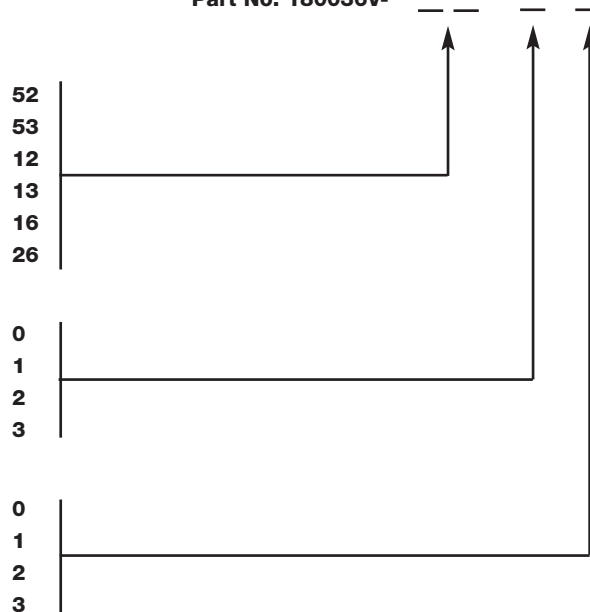

Pump Systems (Only available for purchase in North and South America)

SP Close-Coupled Systems with SCREWLINE Dry Compressing Backing Pumps

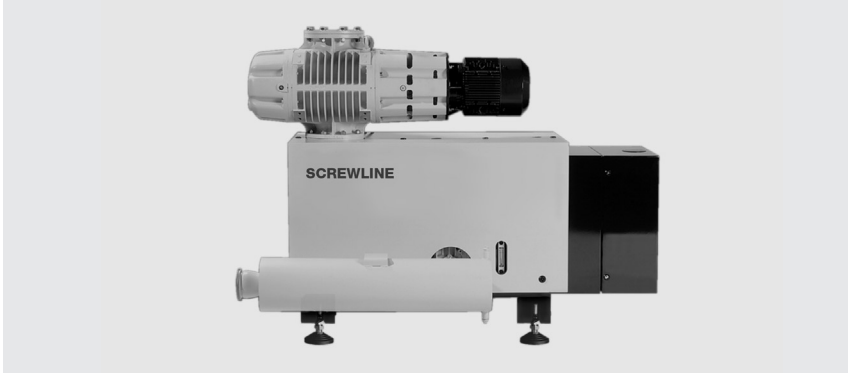

SP close-coupled system

Advantages to the User

- Reduced maintenance and lower operating costs
- Compact close-coupled design without frame
- Oil free compression in multiple pump stages
- Optimum leak tightness with WSU boosters
- Air-cooled
- Assembled and tested

Standard Equipment

- SP630 / WSU1001 close-coupled pump system offering 645 ACFM at 0.3 Torr vacuum
- SP630 / WSU2001 close-coupled pump system offering 1235 ACFM at 0.3 Torr vacuum

Options

- Electrical controls
- Exhaust silencer (loose)
- Inlet filter (loose)

The new SCREWLINE SP630 dry compressing screw-type vacuum pump is an environmentally friendly alternative to traditional oil-sealed rotary piston and vane vacuum pumps. This innovative and robust vacuum pump produces a pumping speed of 371 cfm and better than 0.0075 Torr vacuum. SP630 major advantages include improved environment, reduced maintenance, lower operating costs through less disposal and the elimination of expensive water cooling all with no oil contamination as the need for lubricating oil in the pumps' compression stage has been eliminated.

When used in conjunction with the Oerlikon Leybold Vacuum WSU booster pumps, pumping speeds can be significantly increased while achieving oil-free compression in multiple vacuum pump stages.

Oerlikon Leybold Vacuum WSU boosters offer a canned motor design, which eliminates the need for shaft seals and flanged-on motors. A vacuum tight can separates the motor rotor and stator coils. This unique Oerlikon Leybold Vacuum design provides the advantage of a more leak tight vacuum system. The WSU version booster incorporates a bypass valve feature, which allows for automatic adjustment to varying pressure differentials between the inlet and outlet of the pump. The result is elimination of costly pressure switches / amplifiers and faster pump down while starting at atmospheric pressure with the aforementioned SP630 vacuum pump.

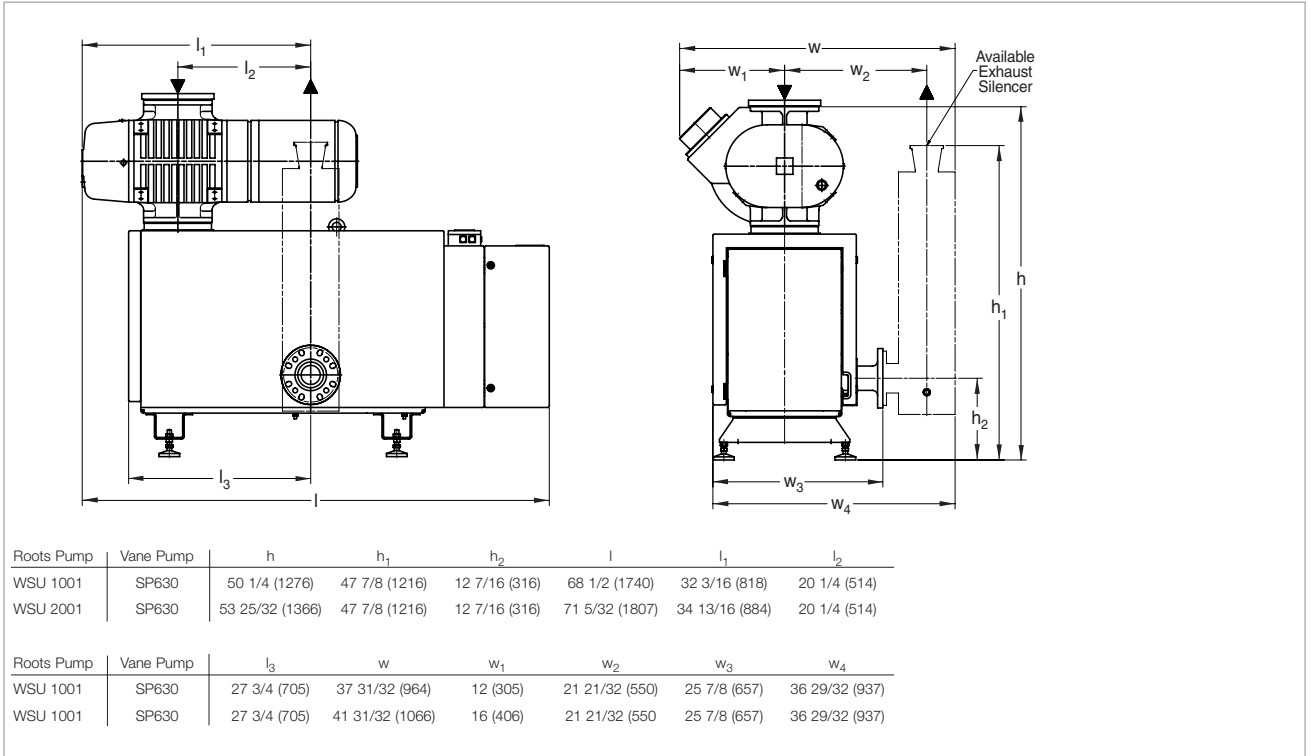

Dimensional drawing for the SP close-coupled system with SCREWLINE SP630 dry-compressing backing pumps

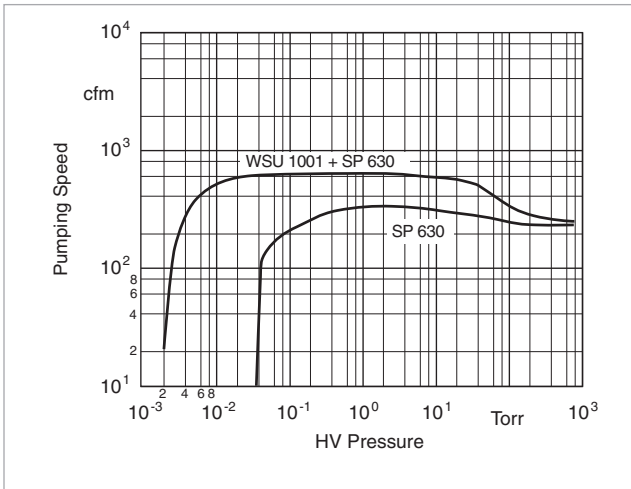

Pumping speed diagram for the SP close-coupled system with WSU 1001 Roots blower and SCREWLINE SP630 at 60 Hz

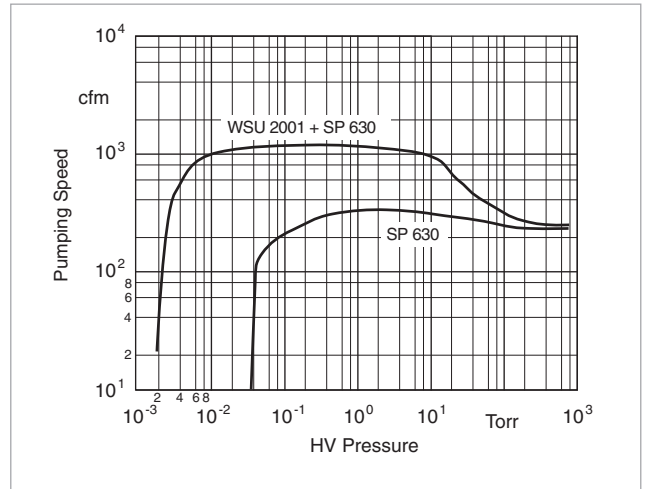

Pumping speed diagram for the SP close-coupled system with WSU 2001 Roots blower and SCREWLINE SP630 at 60 Hz

Technical Data, 60 Hz

SP Close-Coupled Systems

		1001/SP630	2001/SP630
RUVAC (WSU possible)	P2	1001	2001
Backing pump SCREWLINE	P1	SP630	SP630
Pumping speed 60 Hz at 0.3 Torr	m ³ x h ⁻¹ (cfm)	645 (380)	1235 (727)
Ultimate total pressure without gas ballast	mbar (Torr)	< 1 x 10 ⁻³ (< 7.5 x 10 ⁻⁴)	< 1 x 10 ⁻³ (< 7.5 x 10 ⁻⁴)
Installed motor power	kW (hp)	16.2 (21.6)	22.5 (30.0)
Noise level to DIN 45 635 with silencer at 10 ⁻¹ mbar (7.5 x 10 ⁻² Torr)	dB(A)	78	79
Weight, total, approx.	kg (lbs)	870 (1922)	1100 (2430)
Connecting flange			
Inlet port	DN ₁	160 ISO-K	160 ISO-K
Outlet port	DN ₂	100 ISO-K	100 ISO-K

Ordering Information

SP Close-Coupled Systems

		1001/SP630	2001/SP630
RUVAC (WA/WAU/WS/WSU possible)	P2	WSU 1001	WSU 2001
Backing pump SCREWLINE	P1	SP630	SP630
Pump system, complete (adaptor version), pallet mounted, with Roots vacuum pump RUVAC WAU		Part No. 180038V1600	Part No. 180038V2600

Accessories

Sound Proofing

A sound proofing box is available as an optional extra so as to reduce the noise down to the permissible level.

Depending on the size of the pumping system, noise reductions between 15 and 20 dB(A) are obtained using our standard soundproofing arrangements.

Custom designs of the sound proofing box allow the noise level to be reduced by up to 35 dB(A).

The maintenance side is designed as a door component. A window insert may be provided in the door or in the side walls to facilitate checking of the oil levels.

Ventilation is performed by means of an electric fan, the fresh air and exhaust ducts are located within the sound proofing box. Further optional extras which may be fitted include closed air circulation with integrated, water-cooled heat exchanger and a connection port for a central exhaust system.



RUTA RA 3001/S630F/G with sound proofing box

Isolation against Vibrations

RUTA vacuum pump systems produce only slight vibrations. To reduce these vibrations even further, vibration absorbers can be fitted under the pump system.

Dust Separators

Vacuum processes where large amounts of particles or dusts are contributed by the process require special devices to protect the vacuum pumps.

Oerlikon Leybold Vacuum has developed – even for high flow rate applications – special dust separators, which can be installed ahead of the intake of the RUTA vacuum pump systems. The dust separators have two stages. The first stage is a cyclone that collects dust particles of coarse and medium size, the fine dust are trapped in filter elements. Dust separators are customdesigned for the specific process and the required pumping speed.

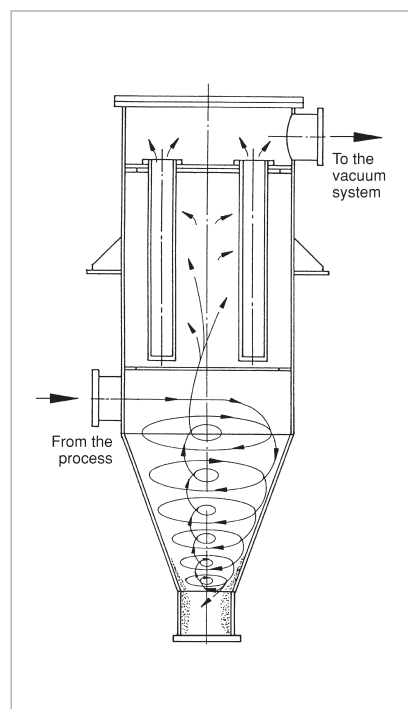

Diagrammatic section through a dust separator

Dust Filter without Cyclone

See below.

Filtering surface suitable for pumping speeds	m ²	0.2	0.5	1.0	2.0	3.0	5.0
min.	m ³ x h ⁻¹ (cfm)	100 (58.9)	300 (176.7)	600 (353.4)	1000 (589)	1500 (883.5)	3000 (1767)
max.	m ³ x h ⁻¹ (cfm)	300 (176.7)	800 (471.2)	1500 (883.5)	3000 (1767)	4000 (2356)	8000 (4712)
Reduction of pumping speed at							
< 1 mbar (< 0.75 Torr)	%	11	11	11	11	11	11
< 6 mbar (< 4.5 Torr)	%	9	9	9	9	9	9
< 20 mbar (< 15 Torr)	%	5	5	5	5	5	5
without dust load							

Frequency Inverter RUVATRONIC RT 5

The electronic frequency inverters RUVATRONIC RT 5/251 to 5/16000 have been designed specially for use in connection with Oerlikon Leybold Vacuum Roots pumps of the RUVAC type.

For each Roots vacuum pump size, a matching frequency inverter is available.

speed will be decreased automatically until the load is reduced to within the pump's limits.

RUVAC Roots vacuum pumps of the types WA, WS and RA (without pressure equalisation line) can be switched on together with the fore-pump at atmospheric pressure. Through this, the pumpdown time can be reduced drastically. The minimum pumping speed of the backing pump needs to be considered in this case.

The main characteristics of the RUVATRONIC RT 5 are:

Simulation of a pressure equalisation line

The software of the frequency inverters is adapted to each pump and ensures that the risk of mechanically overloading the pump can be excluded. In the case of too high pressure differences, the rotational

Pump	Required pumping speed for the backing pump
WA/WS 251	50 m ³ /h (29 cfm)
WA/WS 501	100 m ³ /h (59 cfm)
WA/WS 1001	200 m ³ /h (118 cfm)
WA/WS 2001	410 m ³ /h (241 cfm)
RA 3001	650 m ³ /h (383 cfm)
RA 5001	930 m ³ /h (547 cfm)
RA 7001	1250 m ³ /h (736 cfm)
RA 9001	3240 m ³ /h (1907 cfm)

Operation at up to 3 predefined speeds

Via floating contacts, the pump can be operated at one of the 3 predefined speeds. Switching over to another pre-defined speed is possible during operation.

Operation at any rotational speed

With a 0 to 10 V signal, any speed can be pre-defined to operate the pump between the minimum and maximum rotational speed. The software reliably ensures that the rotational speed cannot drop below the minimum speed or exceed the maximum speed.

Increase in the pumping speed

By operating the Roots vacuum pumps at frequencies over 50 Hz, the nominal pumping speed of the pumps can be increased. Depending on the type of pump, an increase between 20 and 100% is possible.

Note

Please enquire about possible application limitations (process dependent).

Electric Controller

In order to drive all electrical appliances within the pump systems, the pump systems may be equipped with standard control cabinets which contain:

- Motor protection switch (rated for the pumps used in each case)
- Contactors
- Main switch interlocked in accordance with VDE 0113
- Relays for necessary control/sub-systems
- ON/OFF push-button for each pump
- Power supply for the installed monitoring facilities
- Fault indicators arranged on a lamp panel
- Switch-over (through an external contact) from local to remote operation.

The control cabinet may be fitted either to the frame of the pump system or it may be wallmounted.

Beside the standard systems, we manufacture control systems for much more complex systems:

- Remote control module as a 19" rack module (1/4 width, 3 HU). The start/stop push-buttons and the related indicators for operation and fault are located on the front panel
- Pre- and post-operation control
- Pressure dependant control
- Time-dependant control
- Program control
- Control for explosion hazard areas
- Combinations of the aforementioned versions
- Programmable control (PC)
- Vacuum gauge with pressure read-out in the control cabinet.

Pressure Control

Basically there are several ways in which to control the pressure.

The equipment which is supplied as standard for the **DOWNSTREAM** or **BYPASS** control systems selected by Oerlikon Leybold Vacuum consists of:

- Pressure measurement
- Controller with control unit
- Control valve with position indicator
- Engineering.

The Downstream Control System

throttles the pumping speed of the vacuum pump by changing the conductance of the valve.

The advantages offered by this arrangement are:

- No supply of other gases
- Closed system
- The intake pressure of the pump system is lower than its operating pressure (thus saving energy, among other things).

The second method is the **Bypass Control System**. Here the pressure is maintained at a constant level by admitting an additional quantity of gas.

The advantages offered by this arrangement are:

- Simple design
- Much smaller valve
- No reduction of the intermediate pressure within the pump.

In order to design a pressure control system we need the following information:

- Amount of gas
- Type of gas
- Pressure
- Length of the piping
- Type of auxiliary energy (electric/pneumatic)
- Explosion protection required yes/no

Additional complex control arrangements are available, for example with:

- Adjustable pressure characteristic
- Adjustable timing
- Speed control
- Combination with other control facilities.

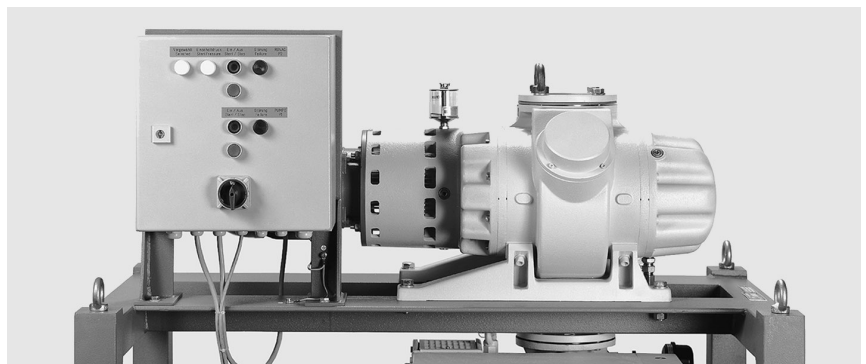

Control panel on RUTA WAU1001/SV200/G

Dust Filter F-xxx-C

The highly efficient dust filters F-xxx-C are fitted to the inlet of the RUVAC pumps. The filter protects the Roots vacuum pumps against the intake of dust.

The dust filters are equipped with an easy to replace filter element. In the case of the filters F-1001-C or larger, the gas enters into the housing above the filter element. Thus the likelihood of puncturing the filter is reduced.

In the case of the dust filter F-501-C, the filter element is protected by a baffle.

All vacuum dust filters are rated for pressures up to 1200 mbar (900 Torr) abs. max.

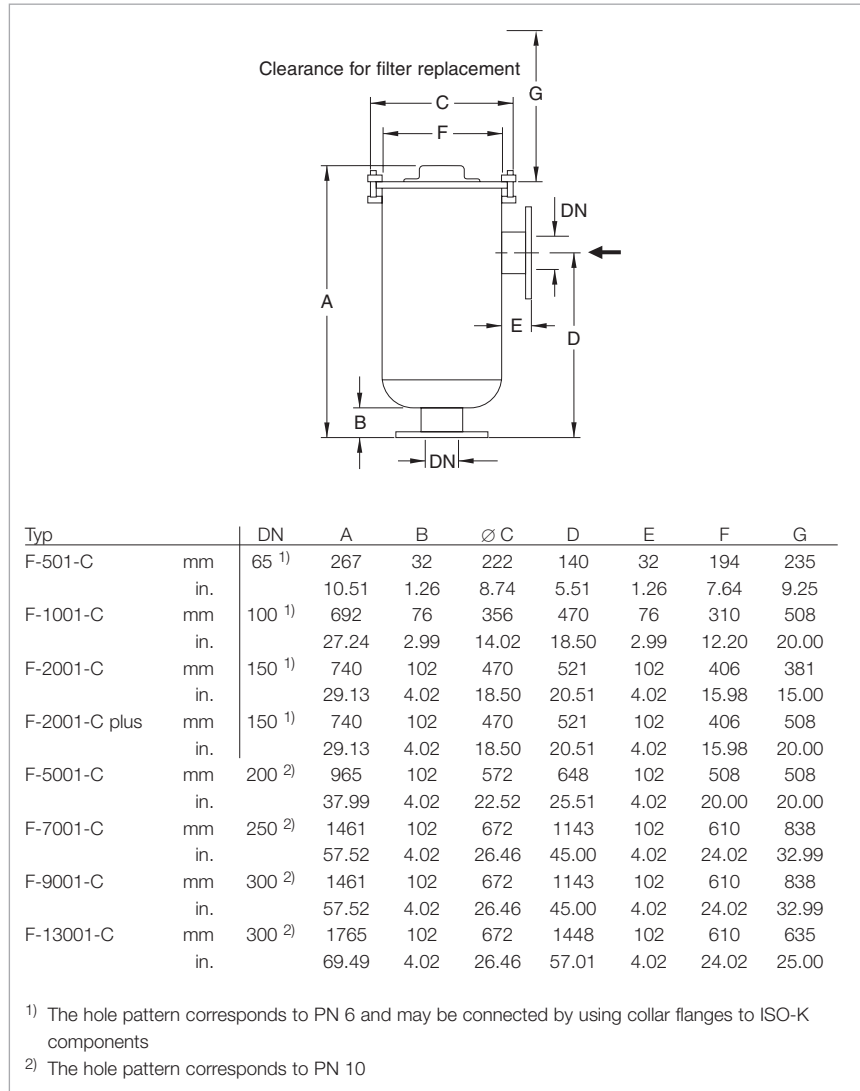

Dimensional drawing for the dust filters F-xxx-C

Technical Data

Dust filter F-xxx-C

Dust Filter		Polyester filter cartridge	Paper filter cartridge
Separation at 10 µm	%	> 99.9	–
Separation at 5 µm	%	> 99	> 99.9
Separation at 2 µm	%	–	> 99
Temperature	°C (°F)	-25 to +100 (-13 to +212)	-25 to +100 (-13 to +212)
Dust filter for WA/WS/WAU/WSU 501 WA/WS/WAU/WSU 1001 WA/WS/WAU/WSU 2001 RA 3001 und RA 5001 RA 7001 RA 9001 RA 13000		F-501-C F-1001-C F-2001-C / F-2001-C plus F-5001-C F-7001-C F-9001-C F-13001-C	F-501-C F-1001-C F-2001-C / F-2001-C plus F-5001-C F-7001-C F-9001-C F-13001-C

Technical Data

Dust filter

		F-501-C	F-1001-C	F-2001-C	F-2001-C plus
Surface area, approx.					
Polyester	m ²	0.4	1.0	1.5	2.6
Paper	m ²	1.3	3.0	4.0	6.3
Weight, approx.	kg (lbs)	7.0 (15.45)	29.0 (64.02)	50.0 (110.38)	51.0 (112.58)

Technical Data

Dust filter

		F-5001-C	F-7001-C	F-9001-C	F-13001-C
Surface area, approx.					
Polyester	m ²	4.5	9.0	9.0	14.0
Paper	m ²	11.5	26.0	26.0	37.0
Weight, approx.	kg (lbs)	83.0 (138.22)	171.0 (377.48)	171.0 (377.48)	209.0 (461.37)

Ordering Information

Dust filter F-xxx-C

Dust Filter	Polyester filter element	Paper filter element
F-501-C Replacement filter element FE-501-C	Part No. 500 001 403 Part No. 500 005 629	Part No. 500 001 404 Part No. 500 005 630
F-1001-C Replacement filter element FE-1001-C	Part No. 500 000 301 Part No. 500 000 313	Part No. 500 000 302 Part No. 500 000 314
F-2001-C Replacement filter element FE-2001-C	Part No. 500 000 303 Part No. 500 000 315	Part No. 500 000 304 Part No. 500 000 316
F-2001-C plus ¹⁾ Replacement filter element FE-2001-C plus	Part No. 500 001 367 Part No. 500 005 631	Part No. 500 001 368 Part No. 500 005 632
F-5001-C Replacement filter element FE-5001-C	Part No. 500 000 305 Part No. 500 000 317	Part No. 500 000 306 Part No. 500 000 318
F-7001-C Replacement filter element FE-7001/9001-C	Part No. 500 000 307 Part No. 500 000 319	Part No. 500 000 308 Part No. 500 000 320 (2 pieces are required)
F-9001-C Replacement filter element FE-7001/9001-C	Part No. 500 000 309 Part No. 500 000 319	Part No. 500 000 310 Part No. 500 000 320 (2 pieces are required)
F-13001-C Replacement filter element FE-13001-C	Part No. 500 000 311 Part No. 500 000 321 (2 pieces are required)	Part No. 500 000 312 Part No. 500 000 322 (2 pieces are required)

Miscellaneous

Checklist for Inquiries

To Oerlikon Leybold Vacuum GmbH

Dept. Solutions

Fax: +49 (0)221/347 - 1277

From company: _____

Name/Department: _____

Phone: _____ Date: _____

Fax: _____ First page of: _____

MAKE USE OF OUR KNOW-HOW !

Simply fax the completed checklist to us. Our engineers will design a pump system which exactly matches your requirements. You will receive an offer shortly.

1. In what kind of application will the pump system be used (e.g. drying, distillation)?

2. Is the process run
 continuously in batches:

3. What is the volume of the vacuum chamber?

_____ m³

4. What pump-down times are required/desired?

_____ min/h

5. What operating pressures are planned?

_____ mbar

6. How high is the ambient temperature?

- when installed in the building:

min. _____ °C / max. _____ °C

- when installed out in the open

min. _____ °C / max. _____ °C

7. How high is the intake temperature?

_____ °C

8. What is the composition of the gas which is to be pumped.

Designation:

a) _____ b) _____

c) _____ d) _____

e) _____ f) _____

9. Quantity (kg/h or Nm³/h), traces (%):

a) _____ b) _____

c) _____ d) _____

e) _____ f) _____

10. In case of materials not commonly listed in the tables please state:

a) Molecular weight _____

b) Thermal capacity _____

c) Vapor pressure _____

d) Viscosity _____

e) Melting point _____

f) Special characteristics _____

11. Must explosion hazard regulations be observed?

yes no

if yes, which? _____

12. What kind of electrical supplies are available?

a) Voltage _____

b) Frequency _____

13. What kind of mechanical connection specifications are planned?

a) Length of the intake line

b) Diameter of the intake line

14. Which cooling media are available (water, brine, etc.)? Which temperature?

_____ min. _____ °C

_____ max. _____ °C

Sales and Service

Germany

Oerlikon
Leybold Vacuum GmbH
Bonner Strasse 498
D-50968 Cologne
Phone: +49-(0)221-347 1234
Fax: +49-(0)221-347 1245
sales.vacuum@oerlikon.com
www.oerlikon.com

Oerlikon
Leybold Vacuum GmbH
Sales Area North/Northeast
Branch Office Berlin
Buschkrugallee 33
1. Obergeschoss
D-12359 Berlin
Phone: +49-(0)30-435 609 0
Fax: +49-(0)30-435 609 10
sales.vacuum.bn@oerlikon.com

Oerlikon
Leybold Vacuum GmbH
Sales Area South/Southwest
Branch Office Munich
Sendlinger Strasse 7
D-80331 Munich
Phone: +49-(0)89-357 33 9-10
Fax: +49-(0)89-357 33 9-33
sales.vacuum.mn@oerlikon.com
service.vacuum.mn@oerlikon.com

Oerlikon
Leybold Vacuum GmbH
Sales Area West & Benelux
Branch Office Cologne
Bonner Strasse 498
D-50968 Cologne
Phone: +49-(0)221-347 1270
Fax: +49-(0)221-347 1291
sales.vacuum.kn@oerlikon.com

Oerlikon
Leybold Vacuum GmbH
Service Competence Center
Emil-Hoffmann-Strasse 43
D-50996 Cologne-Suerth
Phone: +49-(0)221-347 1439
Fax: +49-(0)221-347 1945
service.vacuum.kn@oerlikon.com

Oerlikon
Leybold Vacuum GmbH
Mobil Customer Service
Emil-Hoffmann-Strasse 43
D-50996 Cologne-Suerth
Phone: +49-(0)221-347 1765
Fax: +49-(0)221-347 1944
service.vacuum.kn@oerlikon.com

Oerlikon
Leybold Vacuum GmbH,
Dresden
Zur Wetterwarte 50, Haus 304
D-01109 Dresden
Service:
Phone: +49-(0)351-88 55 00
Fax: +49-(0)351-88 55 041
info.vacuum.dr@oerlikon.com

Oerlikon
Leybold Vacuum USA Inc.
5700 Mellon Road
USA-Export, PA 15632
Phone: +1-724-327-5700
Fax: +1-724-325-3577
info.vacuum.ex@oerlikon.com

Europe

Belgium
Oerlikon
Leybold Vacuum Nederland B.V.
Belgisch bijkantoor
Leuvensesteenweg 542-9A
B-1930 Zaventem
Sales:
Phone: +32-2-711 00 83
Fax: +32-2-720 83 38
sales.vacuum.zv@oerlikon.com

France
Oerlikon
Leybold Vacuum France S.A.
7, Avenue du Québec
Z.A. Courtaboef 1 - B.P. 42
F-91942 Courtaboeuf Cedex
Sales and Service:
Phone: +33-1-69 82 48 00
Fax: +33-1-69 07 57 38
sales.vacuum.or@oerlikon.com

Oerlikon
Leybold Vacuum France S.A.
Valence Factory
640, Rue A. Bergès - B.P. 107
F-26501 Bourg-lès-Valence Cedex
Phone: +33-4-75 82 33 00
Fax: +33-4-75 82 92 69
info.vacuum.vc@oerlikon.com

Great Britain
Oerlikon
Leybold Vacuum UK Ltd.
Unit 2
Silverglade Business Park
Leatherhead Road
UK-Chessington, Surrey KT9 2QL
Sales:
Phone: +44-13-7273 7300
Fax: +44-13-7273 7301
sales.vacuum.ln@oerlikon.com
Service:
Phone: +44-20-8971 7030
Fax: +44-20-8971 7003
service.vacuum.ln@oerlikon.com

Italy
Oerlikon
Leybold Vacuum Italia S.p.A.
8, Via Trasimeno
I-20128 Milano
Sales:
Phone: +39-02-27 22 31
Fax: +39-02-27 20 96 41
sales.vacuum.mi@oerlikon.com

Service:
Phone: +39-02-27 22 31
Fax: +39-02-27 22 32 17
service.vacuum.mi@oerlikon.com

Oerlikon
Leybold Vacuum Italia S.p.A.
Field Service Base
Z.I. Le Capanne
I-05021 Acquasparta (TR)
Phone: +39-0744-93 03 93
Fax: +39-0744-94 42 87
service.vacuum.mi@oerlikon.com

Netherlands
Oerlikon
Leybold Vacuum Nederland B.V.
Proostwetering 24N
NL-3543 AE Utrecht
Sales and Service:
Phone: +31-(30) 242 6330
Fax: +31-(30) 242 6331
sales.vacuum.ut@oerlikon.com
service.vacuum.ut@oerlikon.com

Spain
Oerlikon
Leybold Vacuum Spain, S.A.
C/. Huelva, 7
E-08940 Cornellà de Llobregat
(Barcelona)
Sales:
Phone: +34-93-666 46 16
Fax: +34-93-666 43 70
sales.vacuum.ba@oerlikon.com
Service:
Phone: +34-93-666 49 51
Fax: +34-93-685 40 10
service.vacuum.ba@oerlikon.com

Sweden
Oerlikon
Leybold Vacuum Scandinavia AB
Box 9084
SE-40092 Göteborg
Sales and Service:
Phone: +46-31-68 84 70
Fax: +46-31-68 39 39
info.vacuum.gt@oerlikon.com
Visiting/delivery address:
Datavägen 57B
SE-43632 Askim

Switzerland
Oerlikon
Leybold Vacuum Schweiz AG
Leutschenbachstrasse 55
CH-8050 Zürich
Sales:
Phone: +41-044-308 40 50
Fax: +41-044-302 43 73
sales.vacuum.zh@oerlikon.com
Service:
Phone: +41-044-308 40 62
Fax: +41-044-308 40 60
service.vacuum.zh@oerlikon.com

America

USA
Oerlikon
Leybold Vacuum USA Inc.
5700 Mellon Road
USA-Export, PA 15632
Phone: +1-724-327-5700
Fax: +1-724-325-3577
info.vacuum.ex@oerlikon.com

Sales:
Eastern & Central time zones
Phone: +1-724-327-5700
Fax: +1-724-333-1217
Pacific, Mountain, Alaskan & Hawaiian time zones
Phone: +1-480-752-9191
Fax: +1-480-752-9494
Service:
Phone: +1-724-327-5700
Fax: +1-724-325-3577

Oerlikon
Leybold Vacuum GmbH
Bonner Strasse 498
D-50968 Cologne
Phone: +49-(0)221-347 0
Fax: +49-(0)221-347 1250
info.vacuum.ex@oerlikon.com

Asia

P.R. China
Oerlikon
Leybold Vacuum (Tianjin) International Trade Co. Ltd.
Beichen Economic Development Area (BEDA), Shanghai Road Tianjin 300400 China
Sales and Service:
Phone: +86-22-2697 0808
Fax: +86-22-2697 4061
Fax: +86-22-2697 2017
sales.vacuum.tj@oerlikon.com
service.vacuum.tj@oerlikon.com

Oerlikon
Leybold Vacuum (Tianjin) Co. Ltd.
Beichen Economic Development Area (BEDA), Shanghai Road Tianjin 300400 China
Sales and Service:
Phone: +86-22-2697 0808
Fax: +86-22-2697 4061
Fax: +86-22-2697 2017
info.vacuum.tj@oerlikon.com
service.vacuum.tj@oerlikon.com

Oerlikon
Leybold Vacuum (Tianjin) International Trade Co. Ltd.
Shanghai Branch:
Add: No.33
76 Futedong San Rd.
Waigaoqiao FTZ
Shanghai 200131
China
Sales and Service:
Phone: +86-21-5064-4666
Fax: +86-21-5064-4668
info.vacuum.sh@oerlikon.com
service.vacuum.tj@oerlikon.com

Oerlikon
Leybold Vacuum (Tianjin) International Trade Co. Ltd.
Guangzhou Office and Service Center
1st F, Main Building
Science City Plaza,
No.111 Science Revenue,
Guangzhou Science City (GZSC) 510663, Guangzhou, China
Sales:
Phone: +86-20-8723-7873
Phone: +86-20-8723-7597
Fax: +86-20-8723-7875
info.vacuum.gz@oerlikon.com
service.vacuum.tj@oerlikon.com

Oerlikon
Leybold Vacuum (Tianjin) International Trade Co. Ltd.
Beijing Branch:
1-908, Beijing Landmark Towers
8 North Dongsanhuan Road
Chaoyang District
Beijing 100004
China
Sales:
Phone: +86-10-6590-7622
Fax: +86-10-6590-7607
sales.vacuum.bj@oerlikon.com

India
Oerlikon
Leybold Vacuum India Pvt Ltd.
EL-22, J Block
MIDC Bhosari
Pune 411026
India
Sales and Service:
Phone: +91-20-3061 60000
Fax: +91-20-2712 1571
sales.vacuum.pu@oerlikon.com
service.vacuum.pu@oerlikon.com

Japan
Oerlikon
Leybold Vacuum Japan Co., Ltd.
Headquarter
23-3, Shin-Yokohama
3-chome
Tobu A.K. Bldg. 4th Floor
Kohoku-ku
Yokohama-shi 222-0033
Sales:
Phone: +81-45-471-3330
Fax: +81-45-471-3323
info.vacuum.yh@oerlikon.com
sales.vacuum.yh@oerlikon.com

Oerlikon
Leybold Vacuum Japan Co., Ltd.
Osaka Sales Office
5-13, Kawagishi-machi
Suita-chi
Osaka 564-0037
Phone: +81-6-6393-5211
Fax: +81-6-6393-5215
info.vacuum.os@oerlikon.com
sales.vacuum.os@oerlikon.com

Oerlikon
Leybold Vacuum Japan Co., Ltd.
Tsukuba Technical Service Center
Kogyo Danchi
21, Kasuminosato,
Ami-machi, Inashiki-gun
Ibaraki-ken, 300-0315
Service:
Phone: +81-298 89 2841
Fax: +81-298 89 2838
info.vacuum.iik@oerlikon.com
sales.vacuum.iik@oerlikon.com

Korea
Oerlikon
Leybold Vacuum Korea Ltd.
3F, Jellzone 2 Tower, 159-4
Jeongja-Dong, Bundang-Gu
Sungnam-Si, Gyeonggi-Do
Korea 463-384
Sales:
Phone: +82-31 785 1367
Fax: +82-31 785 1359

623-7, Upsung-Dong
Cheonan-Si
Chungcheongnam-Do
Korea 330-290
Service:
Phone: +82-41 589 3035
Fax: +82-41 588 0166

Singapore
Oerlikon
Leybold Vacuum Singapore Pte Ltd.
No.1, International Business Park
B1-20B, The Synergy
Singapore 609917

Sales and Service:
Phone: +65-6303 7000
Fax: +65-67730 039
sales.vacuum.sg@oerlikon.com
service.vacuum.sg@oerlikon.com

Taiwan
Oerlikon
Leybold Vacuum Taiwan Ltd.
No 416-1, Sec. 3
Chung-Hsin Rd., Chu-Tung
Hsin-Chu, Taiwan, R.O.C.
Sales and Service:
Phone: +886-3-500 1688
Fax: +886-3-583 3999
sales.vacuum.hc@oerlikon.com
service.vacuum.hc@oerlikon.com

oerlikon
leybold vacuum

www.oerlikon.com